



Professional Laminating Systems  
Laminator Manual





**Machine Details**

**Model:** \_\_\_\_\_

Serial # \_\_\_\_\_

Date Of Purchase \_\_\_\_\_

Date Of Manufacture \_\_\_\_\_

Voltage \_\_\_\_\_

Inspector \_\_\_\_\_





|                                   |           |
|-----------------------------------|-----------|
| <b>1 - Basics:</b>                | <b>11</b> |
| #1. Feed Table                    | 12        |
| Feed Table Installation           | 12        |
| Feed Table Side Guide Adjustment: | 12        |
| #2. Mandrels                      | 13        |
| Mandrel Size:                     | 13        |
| Tension Control Knob:             | 16        |
| #3 Laminating Roller.             | 17        |
| #4 Gapping Handle.                | 19        |
| Purpose:                          | 19        |
| #5 Slitters:                      | 21        |
| Slitter Warnings:                 | 22        |
| Slitter Setup and Operation:      | 23        |
| Changing Blades:                  | 25        |
| #6 Pressure Knob                  | 26        |
| <b>#2 Operator Interface:</b>     | <b>27</b> |
| #6. Temperature Control Dial      | 28        |
| Temperature Recommendations:      | 28        |
| #7. Display                       | 28        |
| #8. Power Switch                  | 28        |
| #9. Fans                          | 29        |
| Fan Recommendations:              | 29        |
| #10. Motor Direction Control      | 30        |
| #11. Motor Speed Control          | 30        |
| Speed Recommendations:            | 30        |
| <b>#3 Laminator Setup</b>         | <b>33</b> |
| Film threading fundamentals:      | 34        |
| Film threading fundamentals:      | 34        |
| Idler Rollers                     | 34        |
| Threading Procedure               | 35        |
| Threading Diagrams                | 41        |
| Film Tuning                       | 43        |
| Mandrel Tower Alignment.          | 43        |
| Adjust the mandrel tension.       | 44        |
| Temperature.                      | 45        |
| Roller pressure.                  | 45        |
| Speed.                            | 45        |
| Film Replacement                  | 46        |
| Film Removal                      | 47        |
| Cleaning:                         | 48        |

|                                    |                                     |
|------------------------------------|-------------------------------------|
| <b>Operation</b>                   | <b>49</b>                           |
| General Two-sided lamination:      | 49                                  |
| Film Type:                         | 49                                  |
| Temperature:                       | 50                                  |
| Speed:                             | 51                                  |
| Roller Pressure:                   | 51                                  |
| Fans                               | 53                                  |
| Single sided Lamination:           | 55                                  |
| One sided – general:               | 55                                  |
| Board Stock:                       | 57                                  |
| Cold Lamination                    | 57                                  |
| Shutdown                           | 58                                  |
| <b>Maintenance</b>                 | <b>59</b>                           |
| Cleaning the Laminator             | 59                                  |
| Roller cleaning                    | 59                                  |
| Rubbing pad compound               | 60                                  |
| Brushes                            | 60                                  |
| Cleaning the Slip Ring             | 62                                  |
| Cleaning the motor                 | 62                                  |
| Lubrication:                       | 64                                  |
| Copper Antistatic Tinsel           | 65                                  |
| Roller Care And Maintenance        | 66                                  |
| Operating Guidelines:              | 67                                  |
| Film:                              | 67                                  |
| Cleaning:                          | 67                                  |
| Film Wrap                          | 69                                  |
| Maintenance:                       | 69                                  |
| Troubleshooting                    | 70                                  |
| Overview                           | 70                                  |
| Common Errors                      | 70                                  |
| Glossary                           | <b>Error! Bookmark not defined.</b> |
| Notes                              | 76                                  |
| LIMITED WARRANTY                   | 77                                  |
| CLAIM PROCEDURE                    | 78                                  |
| <b>#6Conversion Tables:</b>        | <b>79</b>                           |
| Temperature: Celsius to Fahrenheit | 79                                  |

Professional Laminating Systems, Inc.  
Hamilton, MT. 59840 406-363-1690

## WARNINGS & SAFETY

**DO NOT OPERATE THIS LAMINATOR WITHOUT FIRST REVIEWING THIS OPERATORS MANUAL IN ITS ENTIRETY.**

NEVER OPERATE THIS MACHINE WITH REMOVED, DAMAGED OR MISSING PARTS - SHUTDOWN AND DISCONNECT FROM THE ELECTRICAL SUPPLY.

IF THERE WERE TO EVER BE A MECHANICAL OR ELECTRICAL MALFUNCTION IMMEDIATELY UNPLUG THE MACHINE

NEVER SERVICE THIS MACHINE WITHOUT FIRST DISCONNECTING THE MACHINE FROM THE ELECTRICAL SOURCE.

DO NOT TOUCH THE HEATED ROLLERS AS THEIR TEMPERATURE MAY EXCEED 350 DEGREES FAHRENHEIT.

**NEVER** ALLOW SHARP OBJECTS SUCH AS KNIVES OR SCISSORS TO CONTACT THE ROLLER SURFACE AS A POTENTIAL SHOCK HAZZARD EXISTS AS WELL AS THE POTENTIAL TO INFLICT SERIOUS AND IRREPARABLE DAMAGE TO THE SILICONE ROLL COVERING OR THE OPERATOR.

CAUTION MUST BE EXERCISED TO KEEP HANDS FROM THE NIP POINT OF THE LAMINATING AND PULL ROLLERS TO AVOID INJURY DUE TO HIGH PRESSURE AND HEAT AT THESE POINTS.

FAMILIARIZE YOURSELF WITH THE REVERSE FEATURE, **DO NOT WEAR LOOSE-FITTING CLOTHING AND JEWELRY AND HAIR MUST BE PUT UP AND KEPT AWAY FROM THE NIP POINT** THESE ITEMS COULD BE PULLED INTO THE LAMINATOR SINCE THE ROLLERS ARE ROTATING.

IF THE SLITTERS (SIDE TRIM KNIVES) ARE USED, USE EXTREME CAUTION WHEN HANDLING THE KNIFE BLADES OR MAKING ADJUSTMENTS AS THE KNIFE BLADES ARE RAZOR SHARP.

LEAVE REPAIRS AND MAINTENANCE TO A QUALIFIED PERSONNEL.

**NEVER LEAVE THE MACHINE UNATTENDED WHILE IN USE.**



SHUT THE MACHINE DOWN AND ALWAYS KEEP ROLLERS GAPPED WHILE THE MACHINE IS NOT BEING ATTENDED. THIS GREATLY EXTENDS THE LIFE OF THE ROLLERS AS WELL AS SAVING \$ IN LOST ENERGY. REMEMBER YOUR NEW LAMINATOR TAKES AS FEW AS 4 TO 5 MINUTES TO WARM UP RATHER THAN 20 OR 30

**DO NOT ALLOW THE ROLLERS TO EXCEED 300 DEGREES** DOING THIS WILL GREATLY INCREASE THE LIFE OF THE LAMINATING ROLLERS – THOUGH YOUR MACHINE IS PERFECTLY CAPABLE OF RUNNING FILM RATED AT 300 DEGREES PRO-LAM RECOMENDS USING A FILM THAT IS RATED AT A LOWER TEMPERATURE - THIS WILL INCREASE YOUR ROLLER LIFE

**DO NOT ADVANCE THE FILM THROUGH THE LAMINATOR WHILE THE ROLLERS ARE COLD THIS MAY RESULT IN THE SURFACE BEING TORN FROM THE ROLLERS BY THE AGGRESSIVE LAMINATING FILM ADHESIVE.**

DO NOT PLACE THE LAMINATOR NEAR ANY VENTILATION SYSTEM AS THIS MAY COOL THE ROLLERS.

USE CARE WHEN CHANGING THE LAMINATING FILM AS THE FILM ROLLS ARE VERY HEAVY AND MAY REQUIRE AS MANY AS 3 OR MORE PEOPLE TO LOAD THE SUPPLY ROLLS ALSO USE CAUTION TO AVOID PINCHING HANDS OR FINGERS WHILE LOADING THE ROLL

# 1 - Basics:

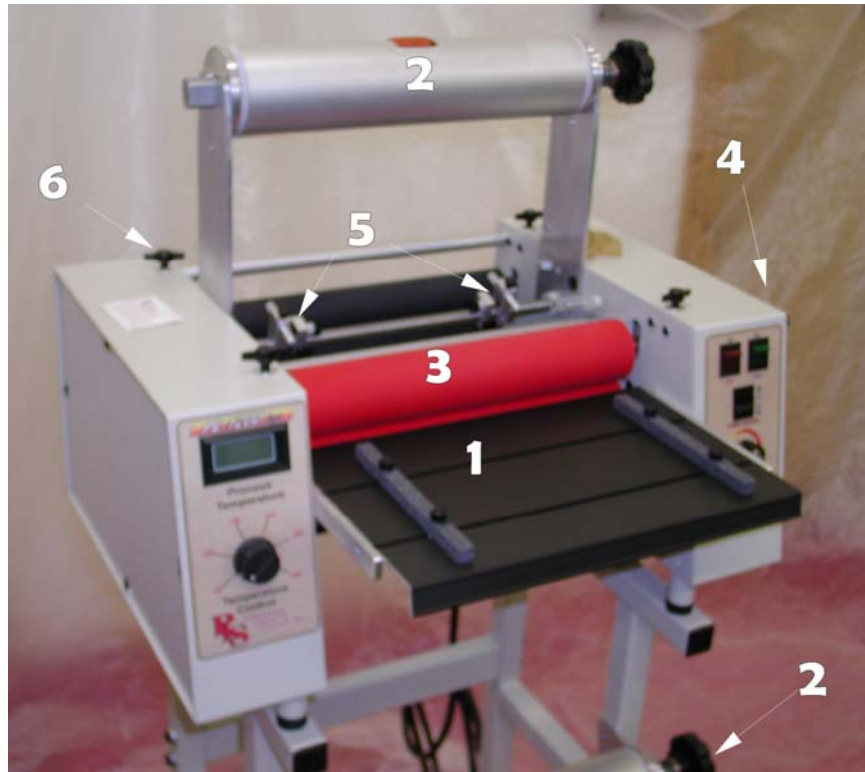

| # | Name               | Function   |
|---|--------------------|--|
| 1 | Feed tray          | Guides material into rollers                                   |
| 2 | Mandrels           | Securely Holds laminating film                                 |
| 3 | Laminating rollers | Heats and nips the laminating film                             |
| 4 | Gapping handle     | Gaps the rollers when not in use (not shown, see page 33)      |
| 5 | Slitters Heads     | Cuts the excess from the side of the web of film               |
| 6 | Pressure knob      | Adjusts the roller pressure, see section for proper adjustment |

## #1. Feed Table

The feed table is used to correctly position the material in relation to the rollers. Located on the surface of the Feed Table is one (or more by option) feed guide.

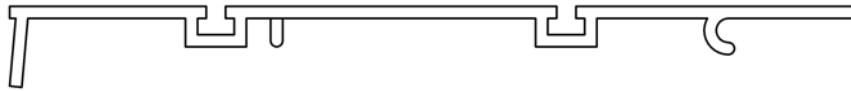

### Feed Table Installation

1. When installing the feed table it should be held level and square in relation with the laminating roller and with the front of the feed tray tilted as shown. 2. Slide the table forward until the pin boss is against the pin and 3. Drop the front down so that the second pin locks the table in place.

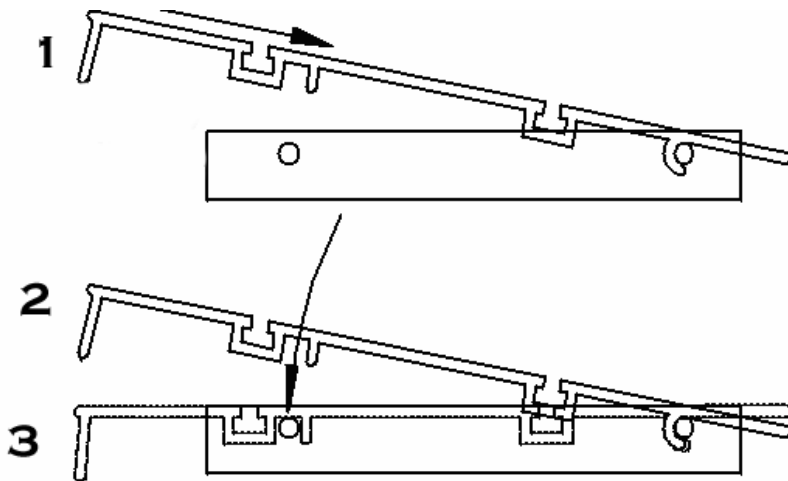

**When placing the feed table onto the laminator, always be sure that the laminator is turned off and the rollers are stationary.**

### Feed Table Side Guide Adjustment:

Using a piece of paper, align the long edge of the paper to the front edge of the feed table. While holding the paper in position, align the feed guide with the other (perpendicular) edge of the paper. Tighten knurled knobs. This preliminary adjustment should bring the feed guides parallel to the film path and only require very small adjustments. Run a piece of paper through while using the slitters (see page\_). Take note of the difference in the alignment of the paper from end to end and split the difference. This should be the amount that the angle of the feed guide should be adjusted. If the front side of the paper is too far to the right move the backside of the feed guide to the right and vice versa.

## #2. Mandrels

### Mandrel Size:

You must match your film core size with the mandrels of your laminator

### 3" Mandrels:

3" Mandrels are standard equipment when the laminator is supplied with a stand. The 3" mandrel is a unique 3" dual locking, interchangeable, ambidextrous, bidirectional mandrel. This mandrel features a rubber roller cam that carefully locks the film roll in place, laterally and radially. In addition, these mandrels feature ambidextrous positioning and 12"+ diameter roll capacity. The purpose of the mandrel is to hold the film in perfect alignment with the laminator and apply a certain amount of friction to the film core as to slow the supply of film to the machine only enough to prevent the roll from "free spooling". This new design does not destroy the core of your mandrel like other designs. In addition, they feature a new locking design that provides more lateral support than in any previous design.

If you desire to use film that is supplied with a 1" core or a 2.25" core, optional mandrels may be available. Please contact your dealer for more information.

### Film: (adhesive out)

Most 3" core film rolls are wrapped adhesive out, when mounting the film on the mandrel, you should make sure that the film leader separates from the supply roll from the front (see film threading, page\_).

### Film: (adhesive in)

Most 1" core film rolls are wrapped adhesive in, when mounting the film on the mandrel you should make sur that the film leader separates from the supply roll from the back, (see film threading, page\_).

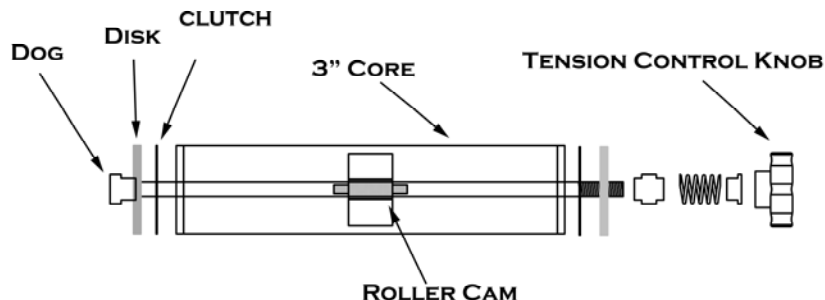

### 1" Mandrels:

The 1" mandrels are designed to be used with film that is wrapped adhesive in. They feature a typical steel drive dog to grip the film, this drive dog is sharp and must not be contacted. This drive dog only works in one direction, it is important that the film is properly installed on the mandrels.

The clip type mandrels are marked on the end, T for the Top Mandrel, B for the Bottom. In the center of the mandrel is a clip that holds the film core to the mandrel. If you are using 1" cored film with the adhesive wrapped out you must use the top mandrel on the bottom and the bottom on the top.

**!!!Be very careful as the 1" mandrel clip may cut!!!**

*(This clip is required to hold the film supply roll tightly; the mandrels are designed to work in only one direction so that film removal will be simplified.)*

### 1" Mandrel Clip:

Each 1-inch mandrel has one mandrel clip – use caution so that you do not cut yourself –. These clips are located in the center of each mandrel they are designed to hold the film to the core of the mandrel when in operation and to aid in film removal from the mandrel by allowing the core to slip when turned in reverse. Take note when the laminator is set up if this clip is holding the mandrel to the film core, or if it is allowing it to slip. If it is slipping, the mandrels may be in the wrong position and should be reversed – see also installation instructions on these mandrels

### 1" Mandrel Clip Orientation

The following diagrams show the proper use of the 1" mandrel respective to film wrapped with the adhesive out the intent of illustration is to demonstrate the internal operation of the mandrel clip. As you can see in the first diagram, when the film is pulled, the core simply turns away from the sharp edge of the mandrel clip and slips past it, in the second diagram you can see that when the film is pulled, the core turns into the sharp edge of the mandrel clip, causing the core to “dig” into the clip, consequently locking the core in one direction only. (the perspective of these diagrams is the top mandrel from the right side of the machine, the bar that the film path meets is the upper idler bar)

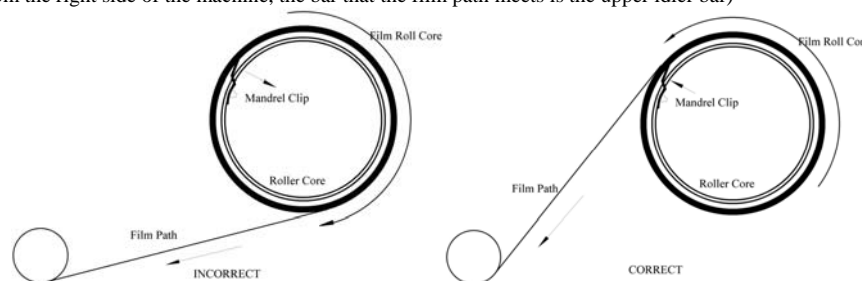

**IT IS IMPERATIVE THAT THE ADHESIVE SIDE OF THE FILM NEVER TOUCH THE LAMINATING ROLLER**

**Installation:**

The mandrels are removable and simply slip into the mandrel towers. The handle typically should be facing the right side of the machine. It may take two people to lift the mandrel onto the laminator because once it has a roll of film on it, it can be quite heavy.

It is a good idea to practice installing the mandrel onto the machine without any film on it so that the process is understood. You will find that the right side will lead the left side when sliding in.

You will find that both right and left sides of the mandrel are “keyed” (*the mandrel end pieces must be turned the correct direction in order for it to drop into place into the towers*)

*See page\_ for proper film threading directions..*

**Use care, when installing the mandrel, not to pinch fingers.**

It is also necessary to allow the right side of the mandrel to drop into place slightly before the left side.

**Locking film to core:**

Once installed into the mandrel towers on the machine, pull some film from the supply roll while holding the core of the mandrel. This will cause the gripper to grab the core and you will feel the film roll lock to the core, turn it by hand just a bit further and you will feel it seat in place.

If the gripping cam does not grab the film roll;

- 1-Hold the film roll stationary and rotate the film core until it grabs.
- 2-Clean the rubber gripping cam
- 3-Replace the rubber gripping cam

**Tension Control Knob:**

The tension control knobs are located on one end of the mandrels that hold the laminating film. They are used to:

- A. Control film tension
- B. Prevent the film rolls from free spooling.
- C. Flatten any film curl
- D. Smooth film lay on the rollers

As a rule, for the highest quality lamination, the lighter the tension, the better. The mandrel tension may also be used to assist in keeping the lamination flat.

- If the laminate curls up when it exits the back rollers, first reduce the upper roll tension then if necessary increase the bottom roll tension.
- If it curls down, reduce the bottom roll tension then if necessary, increase the upper roll tension.

 Please remember to use the minimum amount of tension necessary to insure a crease free and high quality lamination.

During single sided laminations use extra attention to assure that there is zero or minimal tension on the film, as of equal importance is an appropriate film of a high quality and in good condition. In the event that there is excessive film wrinkling on the rollers that show on the laminate, mandrel tension may assist in smoothing this out.

-Do not use mandrel tension to compensate for an incorrectly adjusted mandrel towers. See page\_-

### **#3 Laminating Roller.**

The laminating roller is the heart of the machine. The laminating roller simultaneously heats and encapsulates the product being laminated.

We realized the need for a new technology in laminating when we were aware of the old insurmountable limitations. We understood the need for;

- Unsurpassed thermal controllability.
- A professional quality lamination.
- Unprecedented range of materials and laminates.
- Economical to operate.
- Ease of cleaning.
- Durability.
- Extreme Warm-up times.
- Low maintenance

To achieve these goals, we developed a new patented roller that simply applies the heats to the surface of the roller and not the entire roller assembly like other technologies.

It is very important to preserve the life of the rollers, that you follow the roller care and maintenance instructions on page\_





## #4 Gapping Handle.

**Purpose:**

This handle is for separating the rollers when not in use or for helping to clear film wraps. The rollers should remain in the gapped or raised position unless the machine is in operation.



(Machine shown with alternate tower, disregard differences)

**Please keep the rollers in the gapped position when the machine is not in use.**

By gaping the rollers, you will increase their service life as well as insuring superior laminations. If left in the closed position for extended periods, especially when hot, you

- A. Run the risk of "flat-spotting" them. This phenomenon can result in narrow bands running from one side of the laminate to the other during every revolution of the roller.
- B. Cause heat build up at the nip while the laminator is idle with the rollers heated

To ensure a quality lamination it is helpful that the rollers remain gapped and the fans off during warm up or while the rollers are stationary for an extended period. Failure to do so may result in hot areas on the film perpendicular to the rollers. To remedy this you need to allow the rollers to stabilize. It is much easier to stabilize hot spots than it is to stabilize a cooled roller. To stabilize a roller, simply allow the laminate to run through the laminator very slowly for a few revolutions of the roller or until the hot spots disappear.

**Operation:**

Simply turn clockwise, the rollers will raise and lower with every revolution of the handle.



Gapped / Ungapped

When adjusting the roller pressures make sure that the handle is in the un-gapped position, after making adjustments gap and ungap the rollers to make sure that you did not put too much pressure on the rollers for the cam (gapping handle) to operate.

When gapped, you can rotate the upper rollers by hand for maintenance troubleshooting and clearing film jams. Please be careful, as the front rollers are very hot. For more on this handle please see page 25

✍ The rollers must be in the closed position for successful lamination (encapsulation) to occur.

If it is found that the laminating rollers have flat spots on it due to the rollers not being gapped simply gap the rollers and allow the laminator to go through several heating and cooling cycles and run the laminator without film until the flat spots disappear. The silicone that we use in our rollers is of an extremely high grade and hold nearly no memory for extended periods. We have never had one roller returned because the rollers did not recover from not being gapped. This issue is typically just a nuisance to the operator.

### #5 Slitters:

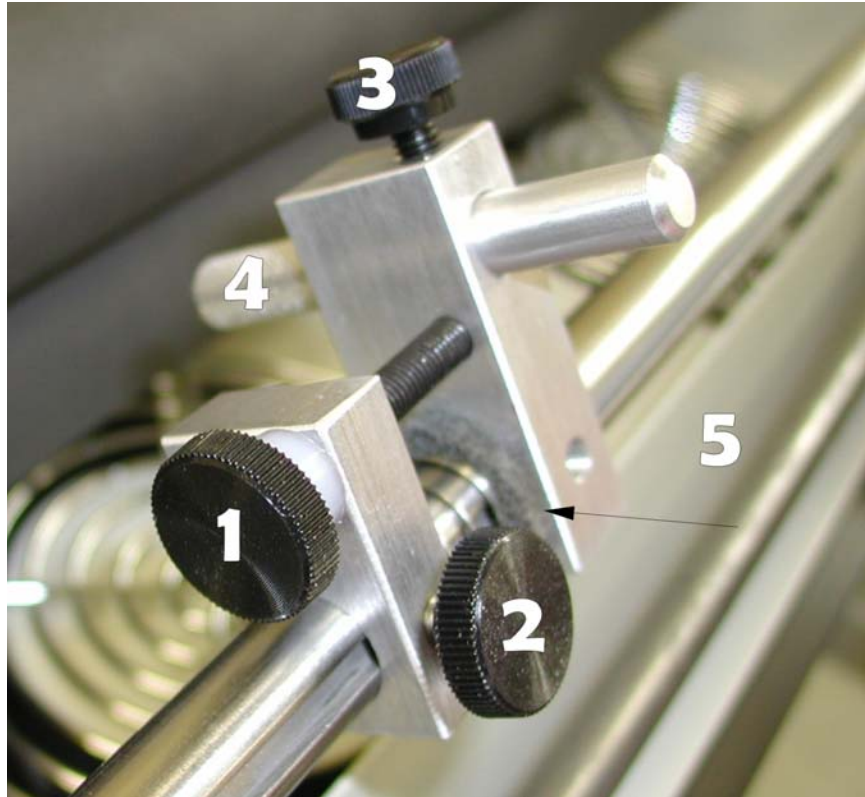

| # | Name                   | Description   |
|---|------------------------|---|
| 1 | Side micro adjustment  | Precise edge margin adjustment                                  |
| 2 | Adjuster lock screw    | Allows major movement of slitter head                           |
| 3 | Slitter angle and lock | Allows for angle adjustment and removal of slitter blade holder |
| 4 | Slitter Blade holder   | Holds Blade   |
| 5 | Spring and lubricant   | Holds and lubricates parts                                      |

**Slitter Warnings:**

!!!Use caution at all times in the vicinity of the slitter assemblies, as the knives are razor sharp!!!

!!!If there is any uncertainty about the operators' competence, remove the blades immediately!!!

**!!!REMEMBER THESE BLADES ARE EXTREMELY SHARP AND ARE CAPABLE OF DISMEMBERMENT OR DEATH THEY SHOULD BE USED WITH EXTREME CARE AND REMOVED WHEN NOT ABSOLUTELY NECESSARY!!**

When the slitters are removed, make sure that they are stored in a safe location to prevent injury.

The slitter assemblies are optional equipment that may or may not have been purchased with the laminator

Never load film on the laminator with the slitters in the down or "trim" position

**Always use sharp blades for slitting operations** this will increase the quality of the lamination and prevent damage to the rear rollers due to blade binding and breakage

Do not use the slitters to cut materials thicker than 3/64" (**approximately .045"**  
**Or the thickness of two layers of 10 mil and 2 pieces of card stock**)

**KEEP HANDS AWAY FROM SLITTERS AT ALL TIMES**

### **Slitter Setup and Operation:**

The slitters that we designed were designed to provide the highest quality slitting possible. Though the design is more complex than most, the quality speaks for the complexity. The slitters are machines of their own, one should realize this and devote some time to understand the correct operation of our slitters. In the next few pages, we will break down the operation of these slitters step by step.



Typical slitter installation

Included with your laminator are the slitter blades, do not install them unless you are using them; always remove the slitter blade holder when not in use.

The blades used and the holder are that same #11 blade and respective knurled holder used for hobby knives (exacto). The function of the holder is the same. You should familiarize yourself with the operation of the holder before use. To insert the blade into the holder, hold the body of the holder and turn the knurled end counterclockwise, this will loosen the blade clamp in the end of the holder. You should then be able to carefully insert the blade into the slot of the blade clamp, then tighten the knurled end. Use the picture below as a reference.

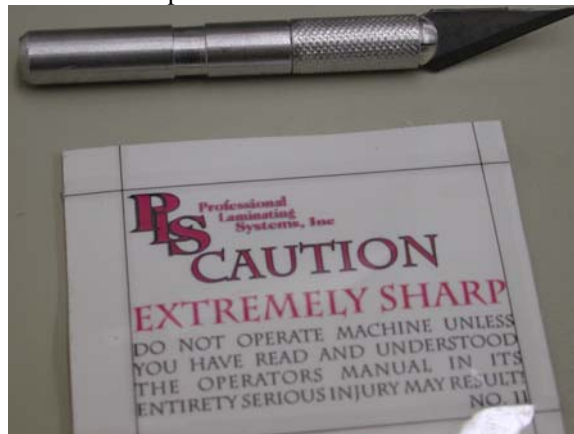

## Slitter Adjustment

1. Align the feed guides on the feed table to the desired location in relation to the film path. Feed a sample piece of paper into the film path.
2. Stop the film when the paper is between the front and rear rollers.
3. Turn the adjustment knob until the slitter block and the adjustment block are separated by about 3/8".
4. Move the slitter blades into the approximate location desired then tighten the knurled knob that locks the adjustment block.
5. Using the actuating arm lower the slitter assembly into the film path.
6. For a more precise adjustment the fine adjustment may now be made by turning the knurled adjustment knob while the film is slowly advancing until the desired edge trim is achieved.

\*In general it takes about four complete turns to move the slitter holder 1/8"

**✎ Do not move or adjust the slitter block while it is in the film, without the film moving.** You must slowly advance the film and adjust the block or remove it from the film path to do so.

**✎ Never leave the slitters in the down, "cut" position while threading the film;** This may result in slitter breakage and permanent damage to the rear rollers

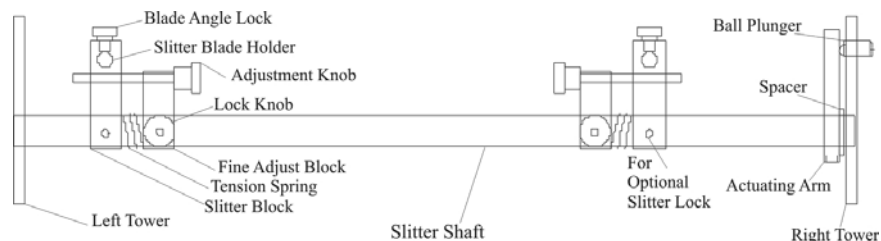

### Slitter angle adjustment

The angle of the cut on the edge of the film is fully adjustable allowing the knife to plane the edge of the film resulting in a minimized edge curl.

To adjust the blade angle,

1. Loosen the blade angle lock ½ turn.
2. Using the diagrams below as a guide, turn the top of the blade holder that protrudes from the top of the slitter block.
3. Tighten the blade angle lock when the desired angle is archived.

In drawing A, the film is cut by the blade and pushed to both sides of the blade resulting in an edge curl on the scrap and the finish piece.

In drawing B, an exaggerated example, the blade planes the edge of the film resulting in curl on the scrap only.

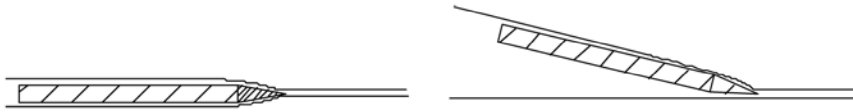

### Changing Blades:

**These blades are extremely sharp and a high degree of care should be exercised while handling them.** It is a good Idea to change or sharpen the blades regularly as this has a direct affect on the quality of the edge finish. We deliberately designed the slitters around an excellent and inexpensive blade (#11 exacto) rather than a proprietary blade so that that this would not be a cost issue with our customers.

1. Retract the blade holders from the film; bring the arm all the way back and against the upper idler bar.
2. Make sure the blade angle lock is hand tight.
3. Turn the knurled area of the blade holder counter clockwise.
4. Remove and replace the dull blade.
5. Tighten the blade holder.

If necessary realign the blade angle.



## #6 Pressure Knob

**Do not use these pressure adjustment knobs to ungap the rollers, before adjusting the rollers. make sure that the rollers are not gapped** (handle on the right side of the laminator)

These adjustment knobs are located in each corner on the top of the side frames, two for the rear and two for the front. They control the amount of pressure that is applied to on the rollers and subsequently the laminate. When running materials thicker than 1/8" always loosen the front adjustment to one turn or less and the rear to one turn or less. To obtain a closer edge seal on thicker papers such as 8 or 12-point cover or card stock it may be necessary to increase the pressure on the front rollers from the factory settings.

Too little pressure on the front rollers will result in poor edge seal and in severe cases a poor surface bond.

Excessive pressure on the front or rear rollers may result in accelerated roller wear, or curled laminate from front to back or corner to corner.

✍ Roller pressure may affect film curl as the film exits the laminator. The laminate should be checked for curl after a roller pressure adjustment.

**After making any pressure adjustments, make sure that the roller gapping handle is still operational**

## #2 Operator Interface:



| #  | Name                | Function   | Page Ref |
|----|---------------------|--|----------|
| 6  | Temperature Control | Adjusts Temperature Set point                        |          |
| 7  | Temperature Display | Shows operating temperature                          |          |
| 8  | Power Switch        | Main Power Switch                                    |          |
| 9  | Fan Switch          | Fans On/Off  |          |
| 10 | Motor Switch        | Selects between, off , forward and momentary reverse |          |
| 11 | Speed Control       | Adjusts the speed of the laminator                   |          |

## Operator Interface

### **#6. Temperature Control Dial**

This knob regulates the process temperature of the laminate. Simply line up the line on the knob with the desired temperature.

#### **Temperature Recommendations:**

Operating temperature varies depending on the type, thickness and manufacturer of the laminating film you have selected. Please use the temperatures recommended by the film manufacturer.

**Under no circumstances should the dial ever be set beyond the 300-degree Fahrenheit setting or more than 20 degrees beyond the film manufactures recommendations.**

After heating up to temperature and before operating, take note of the temperature range that the display shows when idle. During operation, the operator should make sure that the roller heat cycles on and off. This can be noted by the slow rise and fall (up to 1 degree a second) around the noted temperature. If the rollers are unable to achieve the recorded temperature this is an indication that the heaters are always on and do not get a chance to stabilize internally so slow down the speed of the rollers. If the rollers fail to “cycle” the roller life may be reduced.

### **#7. Display**

Shows the operational temperature of the rollers

### **#8. Power Switch**

This switch, located in the upper right of the right-hand control panel activates the heating and temperature control systems incorporated in the rollers. When activated, you will see a numeric temperature displayed in the process control window, located on the left-hand panel.

**Please turn off the heaters and gap the rollers when the laminator is not in use.**

By turning the machine off, you will not only dramatically prolong the life of the rollers-- you will also save a very sizable sum of money in reduced energy consumption. Your laminator should heat up in about 5 minutes depending on the model, you can shut it off when you don't need it and be just minutes' away from laminating when you do. For a faster recovery, it is quite common to simply turn the temperature down when it is not needed, then back up when it is.

**Never leave the laminator unattended when turned on**

Always check that the temperature control dial before turning the machine on.

## #9. Fans

This switch activates the cooling fans. These fans control the temperature of the film as it exits the heat rollers. Their use depends on numerous variables so experimentation and experience is about the only way you can determine their necessity.

**Do not use the fans to facilitate in cooling the laminator during shutdown. Follow the standard shutdown procedure**

### Fan Recommendations:

**Thicker films** (relative to the lamination speed) unless running very slowly

**Thin films** (1.2-1.8 mil.) during medium to high-speed operation

**During slitters use** the fans may reduce an adhesive build-up on the slitter blades.

If the film leaves the rear of the machine at an excessive temperature, the film may show:

1. The film may show a rougher surface finish often from dust and dirt on the rear rollers,
2. The film may show marks from the rear roller that are at right angles to the film path
3. The film may hold the shape it finally cools at outside the laminator.
4. Excessive heat may also cause stretch marks the length of the film or around the edges of the paper.

On the other hand, excessive cooling may cause

- A. Downward curl
- B. Foggy areas in the film
- C. Unusual stretch marks.

### **!!!THE FAN SWITCH MUST REMAIN IN THE OFF POSITION WHEN THE ROLLERS ARE STATIONARY!!!**

Failure to turn off the fans while the laminator is in an idle state will result in abnormal roller cooling, especially on the bottom roller. This may show as cold spots (foggy areas perpendicular to the film path) or failure of bottom lamination.

To remedy this “cold spotting” either

- I. Allow the rollers to stabilize by gaping the rollers and leaving them undisturbed in this position for 5-15 min (with fans off)
- II. In extreme cases shut down the laminator (see shutdown, page 58) and allow the machine to cool to room temperature and then reheat.
- III. In minor cases, the rollers may be stabilized by very slowly running film through until the cloudy spots disappear. This however, may not be an economical solution.

#### #10. Motor Direction Control

The direction control switch is located directly above the speed control. This switch is a three-position rocker switch.

**Off:** The center position of this switch is the off position. This switch should remain in the center or off position when the laminator is not in use. Familiarize yourself with this position. Do not make the mistake of using the speed control to turn the motor off, even though a quick glance may give you the impression that the rollers have stopped turning they may in fact be creeping, resulting in all your film running out on the floor over the weekend.

**Forward:** The normal “forward” setting and the switch will stay engaged after being depressed.

**Reverse:** For clearing jams and cleaning rollers. You must keep the rocker depressed for the duration of time you wish to use this direction. Reverse should only be utilized as a last resort--you can normally clear a jam by gapping the rollers and pulling the film out

**Use Caution when clearing jams as the rollers pose a pinch and burn hazard. It is recommended to have a pair of heat resistant leather gloves (welding gloves) within reach of the laminator for protection**

#### #11. Motor Speed Control

The speed control knob is used to control the speed of the lamination process. This is a variable control, which sets the lamination speed in infinite increments. The fully counter clockwise position is the minimum or position and the full clockwise direction being the top speed of your laminator (see specs for the max available speed).

##### **Speed Recommendations:**

The recommended speed is always relative to every variable of the process including the temperature and material that is being laminated. This is the primary reason that PLS inc. believes it is impossible to have pre-sets on a semi-commercial machine; however, some general guidelines apply.

**Don't be tempted to increase the temperature setting to alleviate the reality of the following limitations this would directly reduce the life of your rollers. Though speed and temperature are related, temperature settings should be thought of more as a standard and speed the variable (see previous page)**

**Film:**

Film type and thickness poses the primary consideration when determining your speed setting. Thicker film requires slower speeds than thinner film. The max setting on the motor control may be considered to laminate 1.2 mil nylon film one side to a thin paper, if you use a low melt 3 mil, the speed may be 40% of this setting, if you use a 10 mil film, the speed may be 10%-15% of this setting. There are many different film made by many different manufactures utilizing quality control practices throughout the world EVERY different variable in the film will change the ABSOULT perfect settings of speed and temperature.

**Material:**

The thickness and thermal properties of the material being laminated also plays a key but less significant roll of the speed and temperature settings needed. The thicker the material the slower the machine must run to thermally saturate the surface of the material. Also, the more thermally conductive the material (plastic or coated papers instead of plain paper) the slower the machine must run, though this does not play as significant of a roll as the film type and thickness it is a serious consideration and may typically affect the speed of the laminator about 10%... thicker films less than 10% thinner films more ~30%. Keep in mind. Unusual and difficult materials may require a speed reduction of 30% to 90% on thinner films.

**Color, Print Saturation:**

Some colors and levels of saturation will “suck” the heat from the rollers requiring the machine to be slowed down. A 100% saturated black page (depending on ink absorptivity) may require a slower setting than a blank page this reduction in speed may compound the reduction in speed as shown above for different materials (reduction of 10% to 30% compounded by the 10% to ~30%).

**Mounting:**

Mounting and / or laminating to a thick substrate will require minimal setting due to thermal saturation



# #3 Laminator Setup

Make sure the machine is plugged into a properly grounded circuit  
Never Operate the Laminator without A Ground  
Refer to “Electrical Requirements” in the installers guide

Check and familiarize yourself with the following functions

- A. The main power switch must be in the “on” position for any other function to work. When activated, the lamp in the switch will glow red.
- B. The Motor direction switch must be in FWD for normal operation, set the speed with the speed control knob. Take note of the Middle “off” position and use this to start and stop the rollers.
- C. Familiarize yourself with the “fan” switch
- D. Familiarize yourself with the gapping handle on the right side of the machine. This gaps the rollers when not in use if you leave the rollers in the gapped position when laminating, it will likely ruin your product.
- E. If at any time there is a malfunction of the machine, immediately disconnect the machine from the wall outlet and contact technical support..

Always keep the rollers gapped when the laminator is not in use



### **Film threading fundamentals:**

#### **Idler Rollers**

There are two idler rollers on a stand model laminator and three idler bars on a table top model, one for the upper laminate and one or two for the lower laminate. These idler bars help direct the film over the rollers to provide a more consistent heat transfer and a high quality lamination.

#### **Top idler**

It is necessary for the laminating film to wrap under and around this idler for proper lamination. By using the idler rollers on the machine, you increase the time that the rollers heat up the film, which results in a better lamination.

#### **Sliding Idler Bar**

The sliding idler bar is a 1" roller located below the lower heated (front) roller as shown in the next picture. Before warming up the machine, take a few moments to "practice" raising and lowering it. Its purpose is to direct the film behind the roller and allow the operator to thread the laminating film without burning their fingers.

To raise the roller place your hands under each end of the roller and gently and evenly raise the roller to the top of the slot, and pull it gently toward you. It will automatically lock in place. To lower it, place your hands under each end of the roller, push it away from you and slightly up then gently lower each end evenly. Do not force the idler if it becomes jammed--gently straighten it out.



#### **Bottom Front Idler**

This idler is only included on laminators that were shipped for table top models. The film is always run below this idler when threading..

## Threading Procedure

1. Load the laminating film on the mandrels (see mandrels on pages \_\_\_\_ for proper use).

**Never allow the dull (adhesive) side of the film to contact the heated rollers.**

2. Insert each mandrel into one of the rolls of film paying very careful attention to the threading diagram with respect to the direction the film unwinds. Center the film on the mandrel then measure the distance between the end of the film roll and the white disk on the mandrel. These measurements should be the same between the top and bottom mandrels.
3. Carefully place the loaded mandrels into their respective saddles on the mandrel towers. Recheck the distance from the film to the disk to make sure the spacing of both rolls is identical. Recheck to make sure that the adhesive side of the film will not contact the roller when it is threaded.
4. Lower the sliding idler bar (located under the bottom roller).
5. Turn speed control to zero and depress the direction switch to the forward position.
6. Pressurize the rollers by rotating the lever located on the right-hand side of the machine clockwise 180 degrees. You will feel the gapping cam lock into position.
7. Set the laminator to the temperature specified by film manufacture. Do not turn on the laminator yet.
8. Pull enough film from the upper roll to allow it to hang about 4-6" below the lower heated roller now is a good time to re-check if the adhesive will contact the roller, if it does the film is mounted on the roll incorrectly. Bring the film around the top idler, (behind and under then forward and up between the idler and the laminating roller) Bring the film over the top of the heated roller down and just past the center point of the lower roller. The film will be in contact with the heated rollers and you would see the adhesive begin to melt if the heaters were turned on,

9. Pull about 1-½ feet of film from the lower roll, bring the film below the lower front idler roller (*if the laminator includes a stand this idler may not exist as it is not required*). With the sliding idler roller in lowered position, wrap the film *around* the sliding idler roller (*below the sliding idler, toward the back. up behind then over the top and to the front again*). Now it a good time to re-check to make sure that the adhesive (dull) side will not come in contact with the roller,
10. Raise the lower idler to its upper position.
11. Turn the power on, then wait for the laminator to reach temperature
12. Bring the film from the lower idler roller around and onto the laminating rollers. The film from the lower supply roll should now stick to the upper film. Make absolute sure that the adhesive is not in contact with the rollers and is facing outward.
13. Now you are ready to complete the threading process. Using a threading card, (included with some laminating film) or a piece of light card board at least 65% as wide as the laminating film and at least 10" long
14. While running the rollers very slowly forward, immediately push and follow the laminating film between the two rollers with the feeding card.
15. When the threading card contacts the nip (where the two heated rollers contact each other), slowly advance the speed while pushing the threading card. Keep the speed as slow as possible. The card will be pulled into the rollers.
16. Immediately monitor the area between the front and rear rollers. You must make sure that the threading card advances directly to the nip between the rear rollers.
17. After the feeding card has exited the machine and is at least 1-foot away from the rollers stop the machine and cut the feeding card from the lamination web. Be extremely careful that the rollers are not contacted with any sharp object as this could damage the rollers and cause poor lamination surface quality

18. Continue to advance the laminating film through the machine. The film will begin to "straighten and flatten itself out". Stop the machine and check both side edges of the film to be certain the top and bottom laminates are precisely lined up. You may need to slide one of the supply rolls a bit to obtain perfect alignment. You will need to slowly run a few feet of film to allow any side adjustments to take affect.
19. To facilitate this process of straightening and flattening the film, it may be necessary to run the feeding board through the laminator again, this will aid in straightening the film. Another trick may be to put tension on the supply roll with your hand to temporarily increase mandrel tension, it may also be necessary to run your hand over the film just behind the idler rollers where there are creases, this may aid in smoothing them.
- 20. If the lamination does not smooth out you must align the towers to the machine see page \_ of the installers guide for the preliminary alignment and then see page 46 for the final alignment.**
21. Also, monitor the film tension as it passes over the heated rollers. Adjust the tension using the knobs located on the mandrels. Keep tension as light as possible while keeping wrinkles and creases that appear on the face of the rollers to a minimum. If there are no wrinkles or creases, the tension is probably too tight. You will find, through experience, that a considerable number of wrinkles can be tolerated before you have a finish quality problem. The trick is to use as little tension as possible or no tension at all. If you use too much tension, the film may stretch, curl or twist.
22. Spend a little time at this point to make sure that "all is well" and you have clear and properly aligned film.
23. Once you have everything adjusted and working well, please take a moment to mark the film roll location on the film mandrels with tape or a marking pen. This step will save you a lot of time and wasted film next time you change the film Or Optional with the three inch mandrels are film core stops After the film has been accurately located, as previously noted, slide the film roll stops against the end of the film roll. Tighten the screws on the film roll stop.
24. Replace the feed table, line up the guides to suit your application and you are ready to begin laminating.
25. To laminate, simply bring the machine up to the desired temperature and rotate the gap control knob to pressurize the rollers. Place the material you desire to laminate on the feed-table, depress the speed control direction switch to the forward position and slowly rotate the speed control knob to the desired process speed.

26. If you have completed all of your laminating chores, gap the rollers and turn the direction control, fans and power off.

**For a higher quality lamination**

- A. Always laminate with the film centered on the roller
- B. When laminating one side, use the top roller.
- C. Clean the rollers between each film change
- D. Regularly check the finished film quality
- E. Never operate the laminator near a fan or vent
- F. Use the fans whenever possible when using the slitters
- G. Only allow the fans to be on while the laminator is in use
- H. Change slitter blades when they dull
- I. Always gap the rollers after use
- J. Use minimal pressures and tension, just enough to get the job done

### Film diagram for threading pressure sensitive film

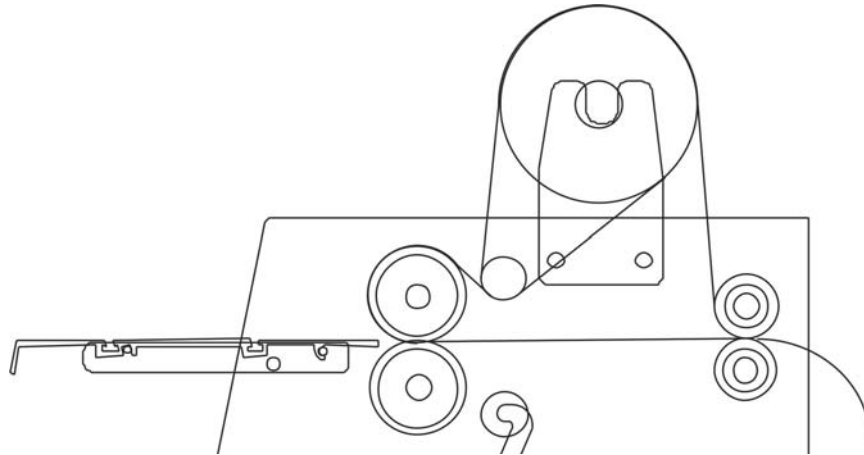

*Notice the path of the release liner*

Thread laminate as typical. However, before feeding laminate through machine separate the liner from the laminate and remove it while the film is being threaded. After the film is through the back rollers by about one foot remove the release liner to the upper idler roller. Bring the liner over the top of the upper film roll down to just before the back rollers. While slowly advancing the film, thread the liner through the rear rollers. After there is about four inches of liner beyond the back rollers stop the motor and grab the liner from the back of the machine and lift firmly this will eliminate any slack that is between the idler roller and the rear rollers, this may need to be done periodically during lamination to take up excess slack.

- It may be necessary to increase the rear roller pressure.
- Be careful during lamination not to let the laminate wrap the rear rollers.
- Use extreme care while using any slitter assembly to prevent wraps and injury.
- It may be necessary to remove the anti-static tensile or thread the film under it, if the film sticks to it

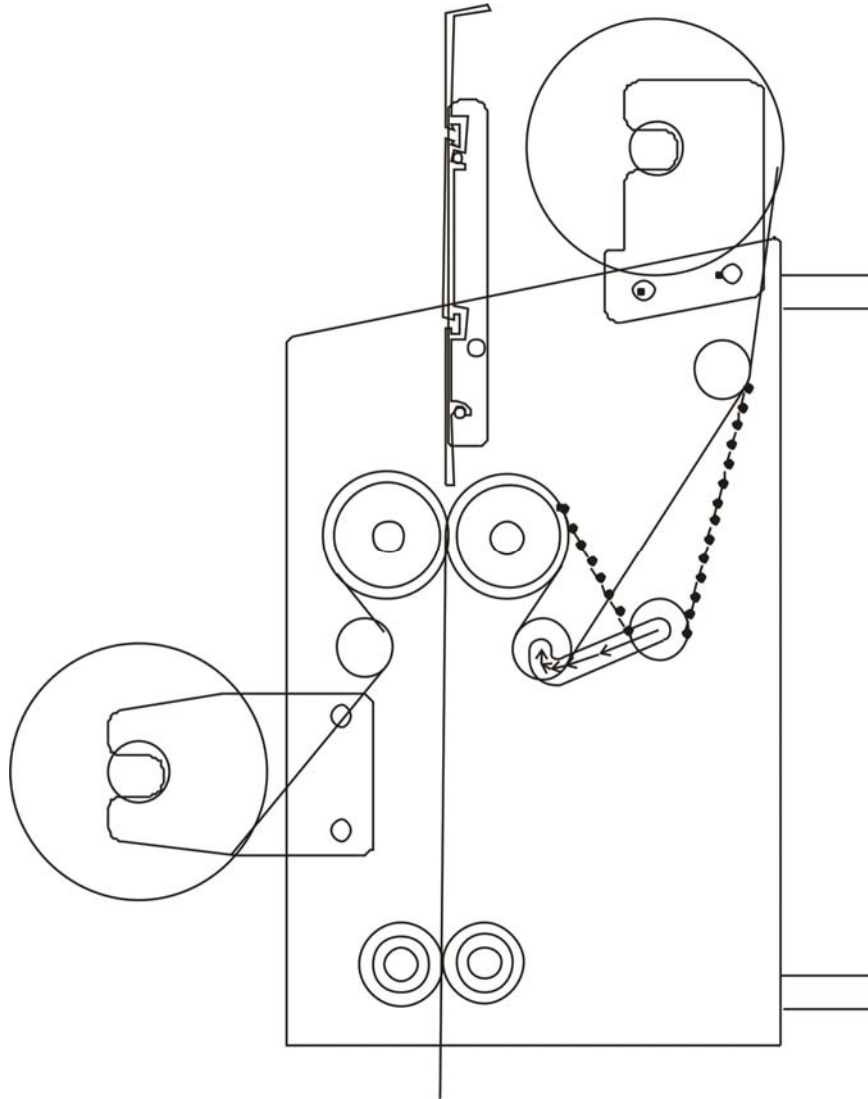

**Tabletop model** shown with adhesive in (reverse wrapped)

**Threading Diagrams**

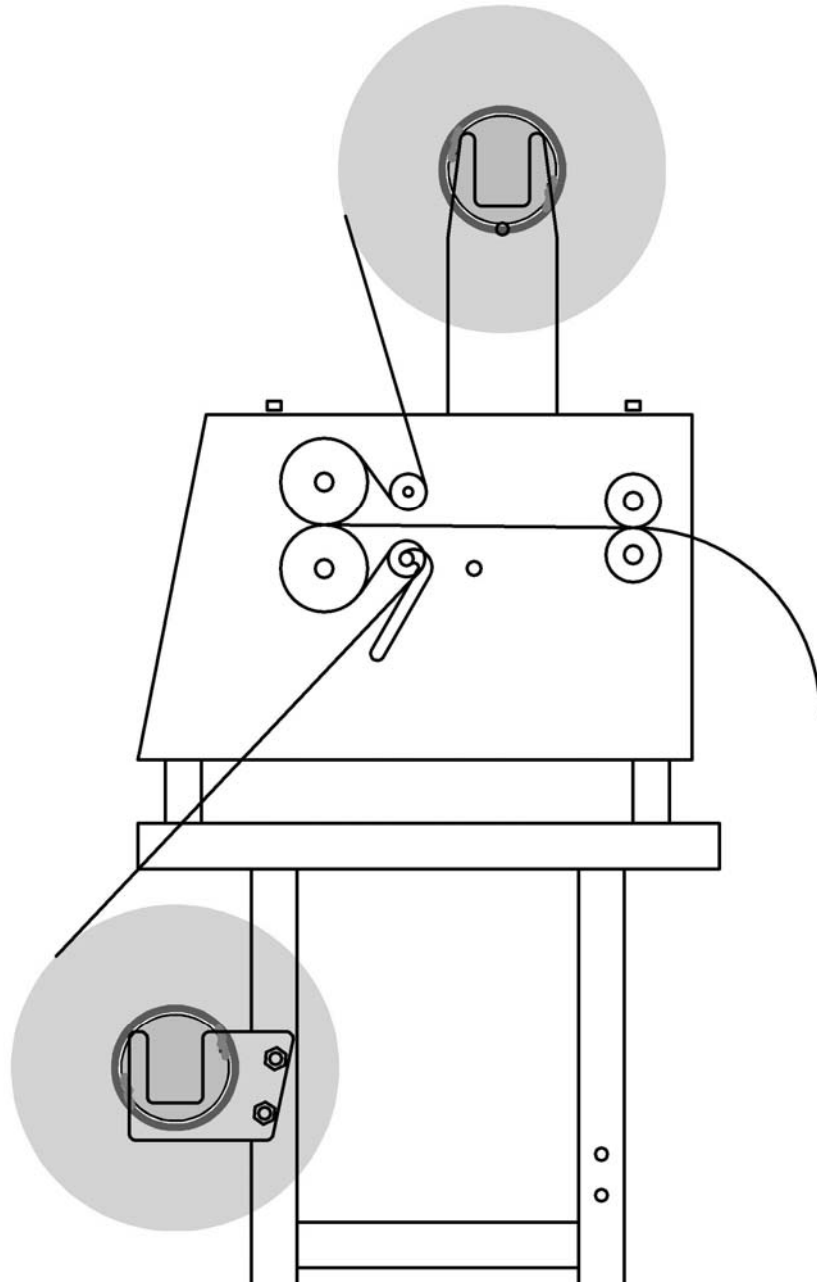

**Threading diagram, adhesive OUT, 3" mandrels**



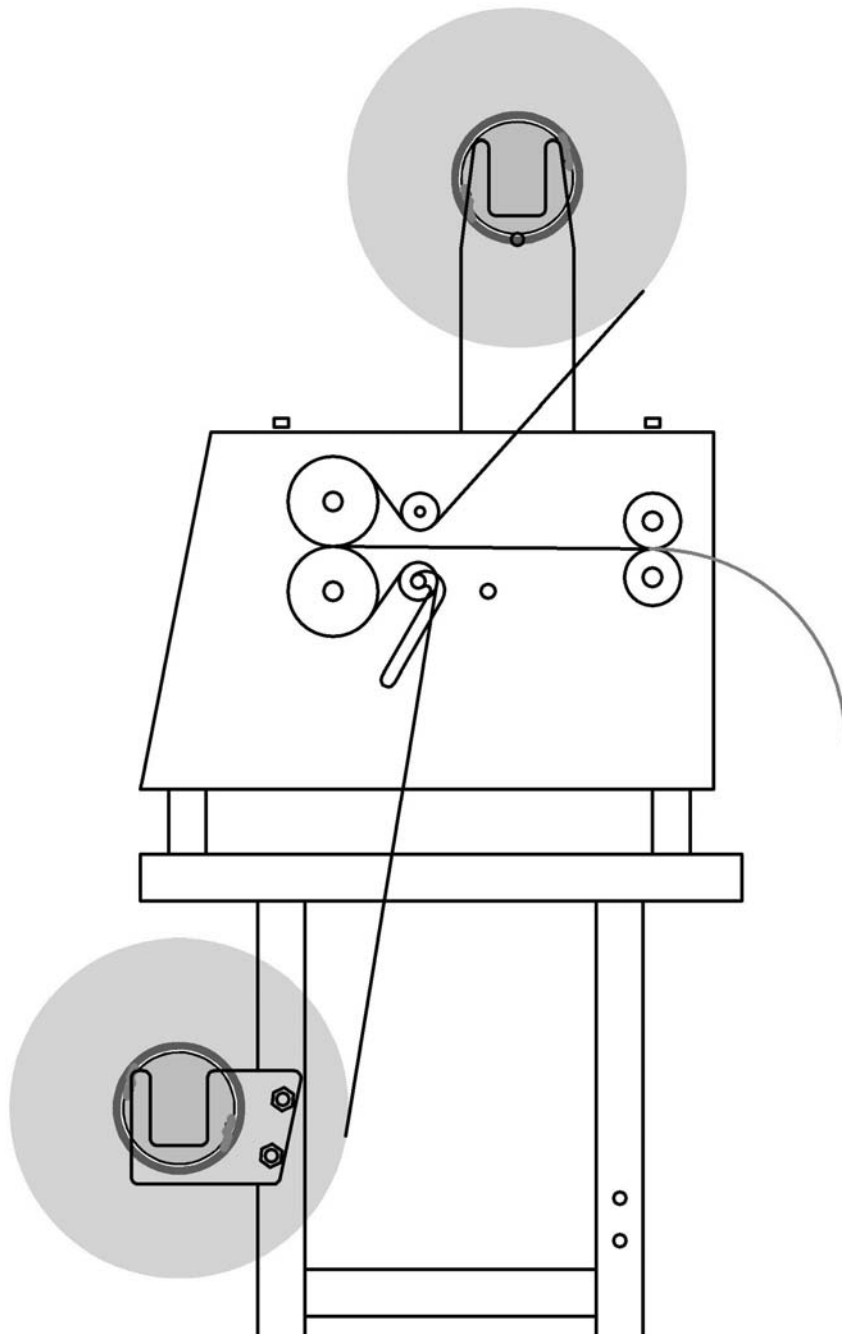

**Threading diagram, adhesive IN, 3" mandrels**

## Film Tuning

Once the laminator has been set up and the film threaded, the laminator should be fine-tuned to the film that you are using. Once the laminator has been fine-tuned, it is not essential to adjust the machine for succeeding film rolls. It may however be necessary to review this paper when one is having problems with the film. The following may be best accomplished by using the thinner films available, such as 1 – 2 mil films.

### **Mandrel Tower Alignment.**

- A. Loosen the mandrel towers just enough that the weight of the film roll doesn't move them but you can do so forcefully.
- B. Make sure that the film is very close to the center of the supply rolls (measure the difference between the distance from the right mandrel tower to the right side of the film roll and then the left side, adjust half the distance of the difference or until centered).
- C. Loosen the mandrel knobs until loose enough to allow the film to spin smoothly but not free wheel.
- D. Turn on the machine and heat to operating temperature.
- E. Slowly run film through the machine while watching how the film comes off the supply roll. This should be even and straight and you should see a line at which the film separates from the supply roll this line should be perfectly parallel with the rollers.
- F. Adjust the mandrel towers, a very small amount at a time until the film is coming off the roll straight or parallel with the rollers.
- G. Tighten the towers when perfect.
- H. This setup procedure should only have to be done one time or when adjustment is lost.
- I. When adjusting the bottom towers, use the 4 allen set screws to tilt the towers as needed.

**Adjust the mandrel tension.**

- A. Typically, the mandrel tension is used to smooth the laminating film as it comes over the rollers into the nip and when to adjust film curl.
- B. If the film is coming over and through the rollers wrinkled, you may add a small amount of tension to the mandrels in attempt to alleviate this. Keep in mind that it is possible for the tension to be too great and actually cause wrinkles.
- C. If too much tension is applied to the mandrels, it can also cause excessive stretch and will result in unsatisfactory lamination.
- D. Single sided lamination should be as loose as possible
- E. Use the mandrel tension to cancel film curl. If the film is curling down loosen the bottom mandrel knob and vice versa, If this cannot be reduced by loosening the mandrel knob it may be counter-acted by tightening the mandrel knob that is opposite of the curl (in this scenario the top idler).

**Temperature.**

- F. Temperature settings are an issue of experience and can affect a wide variety of issues.
- G. Too high of a temperature can cause problems such as blistering, delamination, over heating of the material, insufficient cooling or distortion of the film.
- H. Too low of a temperature may result in unsuccessful lamination, future delamination fogginess in the film or insufficient adhesion
- I. Do not confuse some of these issues with bad film or film that is incompatible with the adhesive or paper

**Roller pressure.**

- J. Use sufficient pressure to encourage heat transfer and adhesion.
- K. Do not use more pressure than is necessary.
- L. Increased rear roller pressure increases stretch.
- M. Increase front roller pressure decreases stretch.

**Speed.**

- N. Speed setting is somewhat relative to temperature; faster roller speed results in a cooler lamination, slower roller speed results in more temperature saturation into the film and paper.
- O. Keep in mind when setting the speed that the fans must cool the lamination down to the point of the lamination adhesive being set – before the lamination exits the rear rollers.
- P. For production, higher speed lamination it may be possible to increase the speed slightly after the rollers get “heat saturated” keep in mind that you must not increase the temperature 20 degrees over the manufactures recommendation. Never run the machine over 300 degrees.

# Film Replacement

It is recommended to remove or replace the film just before the supply rolls run out of film. This will prevent the film adhesive from inadvertently contacting the rollers.

**Never advance the film through the laminator without first heating the rollers.** This will prevent the possibility of tearing the roller covering from the film being “glued” to the rollers, especially when a film with an aggressive adhesive is used

When changing film Rolls simply cut the top and bottom film from the machine (be careful not to get close to the rollers with any sharp object). Run the laminate until there are just a few inches left before one of the webs of film go thru the rollers. Replace the film per previous instructions except stick the new film to the film that is left in the machine. Once stuck, the new film will be pulled thru by the old film.

It is advised to always evaluate if the rollers need to be cleaned when changing film. If so, you will need to remove the film, clean the rollers and replace the film.

### **Film Removal**

It is recommended to remove the film just before the supply rolls run out of film. This will prevent the film adhesive from inadvertently contacting the rollers

**Never advance the film through the laminator without first heating the rollers.** This will prevent the possibility of tearing the roller covering from the film being “glued” to the rollers.

1. Make sure the rollers are **NOT** gapped.
2. Allow the rollers to cool to the point just below the melting point of the film.
3. Lower the sliding idler to its down position.
4. Cut the film from the upper supply roll several inches above the upper idler. **Be extremely careful so that you do not touch the rollers with the device you are using to cut the film!!!**
5. Cut the film from the lower supply roll several inches below the idler in its down position **be extremely careful so that you do not touch the rollers with the device you are using to cut the film with !!!**
6. Cut the film several inches behind the rear rollers (not between the front and back rollers). **Be extremely careful so that you do not touch the rollers with the device you are using to cut the film!!!**
7. Carefully advance the film until the end of the laminate is just coming around the front laminating rollers.
8. Stop the film short of running thru the rollers so that no adhesive gets on the rollers.
9. Gap the rollers.
10. Remove the film by pulling it back out the front of the laminator.

**Cleaning:**

1. Never use an abrasive material on the roller this could cause damage contact pro-lam technical support before attempting this.
2. Never use solvents not specifically recommended for cleaning heated silicone laminating rollers.
3. Professional Laminating Systems recommends using methyl alcohol (methanol) or DX330 manufactured By PPG both of these products are flammable and toxic and should be used with extreme caution in a well-ventilated area with the machine disconnected and no flame source.
4. Pro-Lam recommends using a course cotton mechanics cloth (NAPA part # 7601036).
5. Remove the film from the machine
6. Heat the laminator about 10 degrees beyond its normal set point (no hotter than 310 degrees). Keep in mind that the rollers get really hot and can easily burn you, wear loose fitting thick leather gloves if necessary, welding gloves can be purchased from your local welding supply, Grainger or NAPA.
7. Disconnect the Laminator and “wipe” off the adhesive using the course cotton cloth this may take a bit of work depending on the amount of time that the adhesive has been on the rollers and the type of adhesive it is it may also be necessary to reheat the machine if it cools
8. If you find it necessary to use a roller wash to clean your rollers, follow all safety guidelines applicable to the process.

**Allow the machine to cool and then use methanol or DX330 to remove any dust and grease from the rollers**

# Operation

## General Two-sided lamination:

✍ It is highly recommended that, the product being laminated is meticulously inspected and tested for compatibility, before running a large job. No one likes surprises. Also be aware that certain items cannot be laminated such as thermal paper printouts often used in things such as faxes receipts sonograms and many labeling devices. Valuable one of a kind items, also offer a high risk. If there is **ANY** doubt as to a successful lamination, a high quality copy should be made and that copy laminated. Never laminate anything that cannot be reproduced. Also be aware that there are certain items that should not be laminated such as Social Security Cards, Birth Certificates, etc.

The digital display will read the actual temperature of the rollers. As your laminator warms up, you will see the digital display increase as the temperature rises to the desired temperature setting. When the temperature reaches the setting make sure it stops at the desired set point, you are now ready to laminate. There is no need to allow the temperature to stabilize before using. As you run film through the laminator, it is normal for the temperature to vary by a few degrees or so this will depend upon temperature, speed, film, line voltage, materials being processed, ambient room temperature and air flow across the rollers. If at any time the temperature exceeds the set temperature by 10 degrees, or continues to heat without stopping, immediately unplug the machine and contact Tech support.

## Film Type:

ProLam, inc. recommends using film of good quality from a reputable manufacture. There are many different variables consistent with all films. Of which the most significant are:

- Film type - such as polyester, polyethylene, polypropylene, vinyl, nylon and others –
- Film thickness - such as 1.2, 1.5, 1.8. 2, 3, 5, 7, 10, 15, mils thick -
- Film to adhesive ratios - just 5 mil alone is available many different ratios –
- Different adhesives – this is one of the most important issues when it comes to laminating and especially for wide format laminating as there are many different adhesives and many different inks and papers, an adhesive must be used that is compatible with your ink and media.
- Temperature range - from 160 degrees to 300 degrees **never use any laminate rated with a higher melt point** –

As you can see if you run into difficulty in this area you may need to talk to a film dealer that is familiar with your specific application or printing process and media



**Temperature:**

ProLam, Inc recommends following the temperature guidelines consistent with the type film you are using. Since temperature requirements are different from manufacture to manufacture and film to film there are literally thousands of variables out there and ProLam, Inc is unable to publish a list of every film and our recommendations for that film

**Several guidelines to follow:**

- Start at the manufactures recommendation
- If the film remains cloudy raise the temperature 10 degrees and try it –
- If you see excessive rippling in the film lower the temperature 10 degrees at a time
- Speed and temperature are somewhat related; if you find that Increasing the temperature alleviates some issues slowing the laminator may have similar results.
- If the reason that the temperature is increased is a desire for more speed do not increase the temperature more than 20 degrees beyond the manufactures recommended temperature and **never over 300 degrees**
- If there are unusual problems when the temperature is increased, return it to the recommended temperature and try laminating with the old setting again.
- If the film does not stick, try slowing the machine and then raising the temperature 10 degrees. If raising the temperature does not help, try decreasing the temperature. If this does not work, and you are already following the manufactures recommendations this more often times is a problem with the adhesive rather than temperature.

After heating up to temperature and before operating, take record of the temperature range that the display shows when idle. During operation, one should make sure that the laminator cycles on and off. This can be noted by the slow rise and fall (up to 1 degree a second) around the recorded temperature. If the rollers are unable to achieve the recorded temperature this is an indication that the heaters are always on and do not get a chance to stabilize internally. This practice will greatly reduce the life of the rollers. If the rollers continue to heat much past the set point, immediately unplug the machine and contact tech support.

**Do Not Ever Operate the laminator over 300 degrees. If this is necessary, don't otherwise serious damage may result**

**Speed:**

Speed is once again a function that is very much related to roller temperature, paper temperature, room temperature, laminate thickness or paper thickness however, several guidelines may help.

- Typically when the film is cold it is somewhat foggy and when it heats up to temperature it becomes clear while laminating, a good guideline for general lamination is to watch the film as it comes over the roller, it should become clear before it hits the nip on the laminating rollers
- The thicker the film the slower the speed-
- The higher temperature rating of the film the slower the speed -
- The thicker the paper the slower the speed -
- Foam board – keep the machine running very slowly possibly 1-3 feet per minute depending on your model –

**Roller Pressure:****General:**

Roller pressure is adjusted by turning the cap screws on the top of the laminator.

More pressure may be needed if a thicker stock is being used, and an edge seal is desired. Keep in mind that there are limitations to what your laminator can do. These limitations depend on film thickness and paper thickness. Our PL1200 hp, which is our 12” model, is capable of putting an edge seal on *index* stock with 1.8-mil film. Our 27” laminator is capable of just putting an edge seal on *card* stock with 1.8-mil film. For example, though the 27” is capable of an edge seal on 1.8 mil and cardstock it may not be able to put an edge seal on card stock when two pieces of cardstock are side by side. In contrast, if a thicker film were used, such as five mil, you should be able to laminate card stock side by side and achieve a satisfactory edge seal

If you are trying to get an edge seal on thicker stock, especially with thinner film, you may notice some stretching or wrinkling around the corners of the lamination in many cases this is simply due to a film choice as different films will respond differently. If you are using thick paper in order to end up with a lamination that has more body, it may be more viable to use a thinner paper with a thicker laminate to do so.

When making adjustments take note of how much each screw is turned when adjusting, this way one can make sure that each side is evenly adjusted left to right and also easily returned to the factory setting.

When adjusting the pressure you should find a definite point at which roller pressure is to the minimum, this is characterized by an instant point at which the adjustment screws are easier to turn. What you feel at this point is the bottom of the adjustment knob failing to make contact with

the spring pad when the spring pad is at its uppermost position (when applying pressure make sure that this point is used as a starting point. When the pressure knobs are fully relieved there is a certain amount of preload that still exists on the rollers.

**Wide Format:**

The wider laminators 38" and 44 " models are very sensitive to roller pressure, the roller pressure adjustments on the wide format laminators have less to do with edge seal and more to do with surface bond.

On the wide format laminators, it is possible to get enough pressure on the rollers that they actually bow. If you notice the film is coming around the roller smoothly but when the laminator is run there is air pockets in the center or the film adheres poorly to the center it is possible that you have too much pressure on the rollers.

**Mounting / foam board:**

Typically, when mounting to 3/16" foam board it is desirable to use normal or less pressure. If the primary use of the machine is for mounting, it is recommended that the roller pressure be relieved. When mounting, it may be necessary to guide the item through the machine, especially when the item goes through the rear rollers. This may take a little push to keep the machine from stalling when there is roller pressure and the laminator is running very slowly

**Single sided:**

During single sided lamination, it is best to use as little pressure as possible on the front and rear rollers. For single sided laminating, roller pressures play an important role in a flat lamination. For the more experienced user it may be found that by using a small amount of rear roller pressure it will tend to curl the laminate down.

Make sure that you only use the top roller for single side lamination unless you have a dual control machine.

**Fans**

This switch activates the cooling fans. These fans control the temperature of the film as it exits the heat rollers. Their use depends on numerous variables so experimentation and experience is about the only way you can determine their necessity.

**Do not use the fans to assist in cooling the laminator during shutdown. Follow the standard shutdown procedure**

In general, these fans should be used for:

**Thicker films (relative to the lamination speed) unless running very slowly**

**Thin films (1.2-1.8 mil.) during medium to high-speed operation**

**During slitters use:**

The fans may reduce an adhesive build-up on the slitter blades.

If the film leaves the rear of the machine at an excessive temperature:

1. The film may show a rougher surface finish,
2. The film may show marks from the rear roller that are at right angles to the film path
3. The film may hold the shape it finally cools at outside the laminator.
4. Excessive heat may also cause stretch marks the length of the film or around the edges of the paper.

On the other hand, excessive cooling may cause

- A. Downward curl
- B. Foggy areas in the film
- C. Unusual stretch marks.

**!!!THE FAN SWITCH MUST REMAIN IN THE OFF POSITION WHEN THE ROLLERS ARE STATIONARY!!!**

Failure to turn off the fans while the laminator is in an idle state will result in abnormal roller cooling, especially on the bottom roller. This may show as cold spots (foggy areas perpendicular to the film path) or failure of bottom lamination.

To remedy this either

- I. Allow the rollers to stabilize by gaping the rollers and leaving them undisturbed in this position for 5-15 min (with fans off)
- II. In extreme cases shut down the laminator (see shutdown, page 58) and allow the machine to cool to room temperature and then reheat.
- III. In minor cases, the rollers may be stabilized by very slowly running film through until the cloudy spots disappear. This however, may not be an economical solution.

It may be desirable for heat activated foam board to cool under pressure which would mean you would have to turn the fans off and allow the rear rollers to cool the adhesive when the board contacts them

**Single sided Lamination:**

The Series II laminators may be used for single side lamination with specifically the smaller models for items such as book covers. These laminators are capable of laminating short-run one-sided applications

**One sided – general:**

1. For good results the laminate that you use should be specifically designed for one-sided applications ProLam recommends using nylon films these film typically are designed to breath and move with the paper however many of our customers successfully use polypropylene and vinyl.
2. We recommended you use a laminating film that is slightly narrower than the product being laminated so to prevent the adhesive on the film from touching the laminating rollers.
3. Try to not allow any film adhesive to contact the bottom roller. Some film adhesives stick to our rollers others do not.
4. While threading, the films make sure to follow the threading card with a scrap page that is wider than the film. This page will sit between the two laminating rollers to minimize film contact.
5. While laminating, either butt the pages together or overlap (shingle) the pages and trim the paper after lamination.
6. Use minimal or no tension on the mandrel. This greatly affects film curl.
7. Always laminate using the top roller NEVER the bottom roller. This will overheat the machine and cause permanent damage to the roller.
8. Always gap the rollers when not in use.
9. Use of the fans will affect film curl.

### **Production run one-sided lamination Modification**

For production run one-sided lamination, the machine requires a simple modification as follows. Make sure to follow all safety procedures as described in this manual.

This modification will help in reducing adhesive buildup on the bottom roller, it may reduce film curl and will greatly increase the life of your unused roller.

1. Unplug the machine. Never work on the laminator while it is energized.
2. Remove the right-hand side panel
3. Remove the lower roller brushes these are located inside the machine on the end of the lower roller. On the end of the roller is a slip ring. Contacting the lower slip ring are two brushes contained in two brush holders. These brushes must be removed. On the backside of the brush holder is a cap that holds the brush in place remove this cap on both of the brush holders. The spring that the brushes are attached to will move out, you may now pull on this to remove the brushes.
4. Replace the caps and side panels. Keep these brushes for future use.

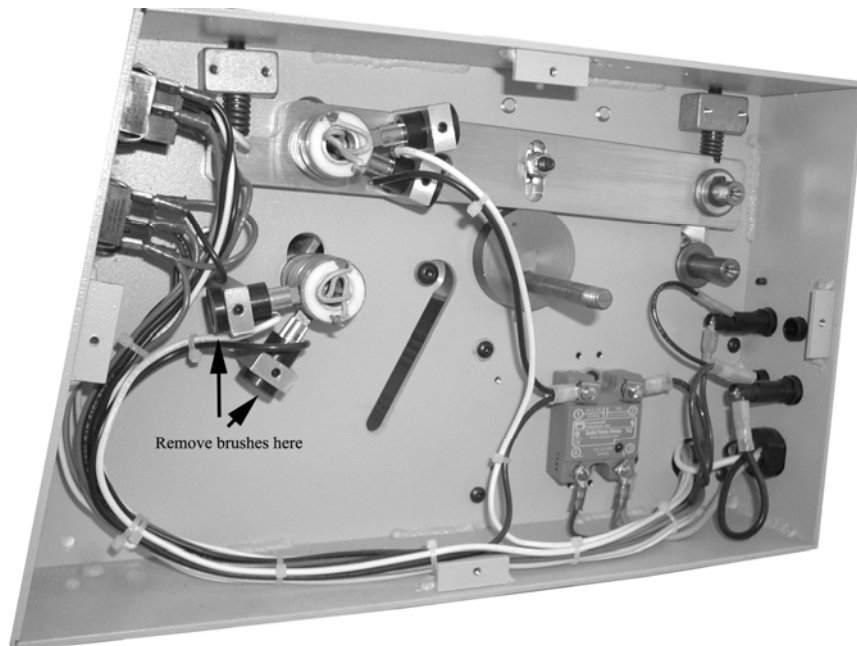

**Board Stock:**

Your series II laminator is capable of laminating and encapsulating a wide variety of materials up to ¼” thick

When laminating board stock the roller pressure adjustment knobs must be fully relieved.

The speed at which board stock is laminated should be much slower to allow the laminator to heat the board sufficiently.

Wide format printer paper may shrink when laminated depending on the type and moisture content this may cause a wide variety of problems.

We recommend using either a heat sensitive board or an adhesive such as 3m-77 and applying the paper to the board stock prior to lamination.

**Cold Lamination**

Your laminator is very capable of laminating one-sided cold lamination using either the machine itself or the optional release liner winder.

Several points to be aware of when laminating using a cold pressure sensitive laminate are:

- A low temperature (100-150) may greatly improve the output and anneal the film
- If a two-sided lamination is desired laminate one side, remove the piece from the film web and laminate the other side.
- Pay extra attention that the film does not wrap around the rollers since the adhesive is in contact with the rollers
- When finished make sure that the film is removed or there is a piece of paper protecting the rollers from the adhesive when not in use
- Do not use a temperature great enough to actually liquefy the adhesive.



## **Shutdown**

The Laminator should be shutdown when not in use for a period longer than five minutes. If the laminator is left on while not in use the roller temperatures may drift and cause poor lamination. The standard shutdown procedure is as follows:

1. Clear the laminated material from the laminator.
2. Shut off the fan switch.
3. Shut off the heat switch or reduce temperature below 160 degrees.
4. Reduce roller pressure if needed.
5. Gap the rollers.
6. Place the motor direction switch to its mid point or off position.

**Attention:** After a long, high speed run on a high performance model laminator, while using a high temperature film (275 degrees Fahrenheit or more), it may be necessary to slow the laminating rollers to a stop or run the last 5-6 sheets of material at a quite slow speed. This will prevent the rollers from overheating due to the built up core temperatures.

**The fans should never be used to aid in cooling the laminating rollers during shutdown**

# Maintenance

**Before beginning a procedure, always read it thoroughly**

**Never remove any service panels from the machine without first disconnecting the electrical supply.**

## **Cleaning the Laminator**

The surface areas of the machine should be periodically cleaned with a damp cloth and a mild detergent. Do not spray any cleaning solution on or near the laminator as this may cause irreparable damage to the rollers.

## **Roller cleaning**

Removal of an adhesive build up on the rollers should be done during every film change

To clean the front rollers: Remove the film and mandrels, remove the feed tray, Heat the machine to temperature and then using a rough cotton cloth, wipe the adhesive off the rollers leather gloves may be needed as protection from the high heat. Most film adhesives are easily removed from the rollers,

**Under no circumstances should any abrasive material be used to clean the rollers**

To aid in cleaning the rollers isopropyl alcohol of 98% or better (or any roller wash designed for heated silicone laminating rollers only) may be used to separate the adhesive from the rollers. After removing the adhesive from the rollers, use isopropyl alcohol of 98% or better to remove any dust or remaining adhesive from the rollers.

**Use caution when using alcohol or any flammable solvent to clean the rollers**

Always disconnect the laminator from the electrical supply before cleaning.

Please review “roller care and maintenance on page \_\_\_ before cleaning your rollers.

**Rubbing pad compound**

The only regular lubrication required on your laminator is the rubbing pad assembly.

The rubbing pad is located on the right hand side of your laminator, inside the panel on the swing arm near the end of the top laminating roller it consists of a virgin felt pad saturated with a high temperature lubricant

The lubricant used on this component is an unique high temperature electrical insulating grease that does not harden it is recommended that this lubricant (rubbing pad compound) be purchased through your dealer or through us directly

Application of this item should be made when the display temperature starts to fluctuate erratically

When the machine is opened for service the integrity of the rubbing pad and related components should always be inspected

The equivalent of a ¼” bead of compound should be applied perpendicular to the rollers onto the slip ring once applied run the machine without any film on it for about 10 minutes. If the temperature does not stop to fluctuate, inspect the brushes.

**Brushes**

Power brushes only need to be replaced when damaged; it is very unusual for these to wear out

Temperature sensor brushes periodically need to be replaced.

These brushes are made of a copper alloy and will wear with time. If the rubbing pad dries out and no longer provides a lubricant to the brushes, wear will be greatly accelerated.

The brushes are manufactured with a radial point ground on each end of the brush. Wear may be identified by the amount that this tip has worn off. The brush may be removed and turned around to use the point on the other end just as long as there is still enough taper on the old end so that the spring can keep the brush centered.

If replacement brushes are needed these may be purchased through your dealer or through us directly

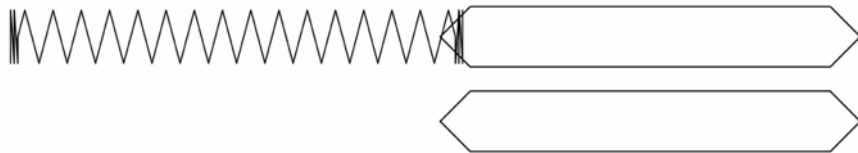

*Rtd brush, note taper on each end (magnified view, brushes are only 1/8 diameter)*

When the brushes are inspected, take note of the condition of the slip ring and that it has not been grooved to badly. If it is seriously grooved and gulled, it should either be polished with scotch brite or replaced. If after replacing the brushes, the condition continues, see temperature fluctuation in troubleshooting.

### **Cleaning the Slip Ring**

This procedure must be performed if there is an erratic and sudden fluctuation in the displayed temperature while the laminator is in operation. Follow these steps and all safety precautions. This procedure is only necessary if the temperature fluctuates when the upper roller is rotated by hand and the roller direction is in the off position.

1. Disconnect the laminator from the electrical supply and allow it to cool.
2. Gap the rollers.
3. Remove the left-hand side panel.
4. Inside the left-hand side panel protruding from the upper roller is the slip ring for the Temperature controller.
5. Using scotch brite or a similar material, remove the carbon and oxidation build up from the slip rings. Rotating the upper roller by hand may facilitate this process.
6. Apply rubbing pad compound. See rubbing pad compound on page 59.

### **Cleaning the motor**

This procedure must be performed **only** after the slip rings have been cleaned and the displayed temperature continues to fluctuate **only** while the motor is operating and the front upper roller is gapped and stationary. This is not typical; this should only be performed as a last option.

1. Disconnect the laminator from the electrical supply.
2. Remove the left side panel upper fan deflector and fan panel.
3. Remove the motor mounting screws accessible from the inside of the left frame.
4. Remove the chain and rotate the motor to access one of the brushes on the side of the drive motor. Remove one of the brushes making sure to keep track of the direction the brush is removed.
5. Apply a very small amount of slip ring compound to the contact area of the brush.
6. Replace the brush making sure that it is replaced the same direction it was removed.
7. Replaced the motor and chain. Apply mild pressure to the motor for chain tension and tighten the motor bolts.
8. Replace the side panel, upper fan panel and fan deflector.
9. Plug the laminator in and run the motor for a few minutes on the maximum setting.



## **Lubrication:**

### **Roller lubrication**

The bearings in your laminator are permanently lubricated; they typically require replacement rather than lubrication. Replacement of your bushings is quite unusual, the bearings that are installed into your laminator are rated for a much more severe duty than your laminator could possibly see. If you must, you may oil the bushings on the laminator using a 10-weight synthetic high temperature oil. Unplug the machine. Using a long small tube type applicator apply two drops of oil to the roller shafts next to the respective bushings. Do not get any oil on the rollers and do not damage the rollers with the applicator.

### **Mandrels Lubrication**

The mandrels are also permanently lubricated and **MUST NOT** be lubricated as the lubricant will migrate and destructively affect the friction characteristics of the clutch face and clutches. As in a automobile, one would never lubricate the brakes. Hub replacement is the only solution to wear. If one finds it is necessary to lubricate the mandrel knob, remove the knob, using a ½-13 (coarse thread) bolt that has threads about 2” in length and apply a dry lubricant, such as dry graphite, to the threads. Thread the knob on it, back and forth several times. Remove the knob, blow it off, and wipe off any excess graphite from the outside. Reinstall the knob.

### **Chain Lubrication**

When the machine is open for maintenance take note of the condition of the chain and sprockets and lube if necessary.

The chain should be periodically lubricated, with a high temperature grease (gl 4), when necessary.

### **Cam lubrication**

When the machine is open for maintenance, take note of the condition and existence of grease on the cam and following surfaces if necessary grease with a high temperature dry lubrication grease

### **Pressure Block Screw Lubrication**

It may be necessary to lubricate the pressure block screw threads if it becomes difficult to turn

1. Remove the screw take note of how many turns it takes to remove each screw so that it may be returned to its original setting once replaced.
2. Using a high temperature grease or an anti-seize compound, apply it to the threads and the tip of the screw
3. Replace screw, verify success

## Copper Antistatic Tinsel

### Laminator antistatic

Anti-Static Tinsel is designed for optimum performance. It eliminates static with the “self energizing” or inductive principle. That is, when sharp points are present in a strong electrostatic field, interchange of electrons occur between the sharp points, thereby ionizing air, and eliminating or neutralizing static electricity. The tinsel does not have to touch the film.

### Replacement

Anti-Static Tinsel is constructed of finer copper strands to obtain a sharper point. The strands are interspersed to obtain the maximum interchange of electrons: but not so dense as to make it an easy collector of paper dust and other foreign particles. Since clean sharp points are essential, tinsel should be replaced whenever it becomes “dirty” with foreign substances or when an increase in static is noticed. Often a good indication of this is an increased tendency of the film to wrap around the rear rollers

### Release Liner Winder anti static

The release liner winder has an internal antistatic bar that rubs against the inside of the tube and grounds to the shaft. If this fails, there will be a remarkable and quite annoying static charge that is built up. If the static bar is removed, this static charge will accumulate until it can bridge the 1” gap to discharge. To replace the anti static bar lie the liner winder tube on a table, while using a punch with a small tip, so that it sits in the taper on the end of the shaft and drive the shaft and the plastic hub out. Replace tinsel and reassemble.

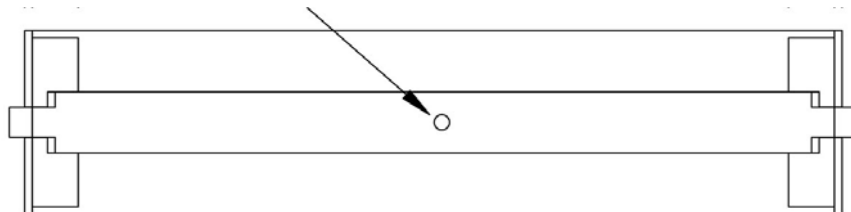

Antistatic bar location on the release liner winder shaft



## **Roller Care And Maintenance**

This paper is applicable to the revolution series heated laminating rollers built by professional laminating systems only. Using these guidelines on other laminators or rollers could cause serious damage to the roller these guidelines should be used in addition to the instructions and manual provided with your machine.

### **Precautions:**

- Before attempting to perform the following, you must read and understand this paper in its entirety and read and understand your operating manual and any other documentation relevant to any procedure that you may attempt. Follow all safety precautions stated or unstated.
- Do not burn yourself, the rollers are very hot, use gloves.
- Keep any sharp or metal objects away from the rollers if you must cut the film off the machine allow a 6” “buffer zone” away from the rollers.
- Keep all clothing and jewelry away from the machine if you have loose fitting clothing remove it or tuck it away (such as a tie, jewelry or jacket) and keep your hands and fingers away from the rollers while in operation

### **About your rollers:**

Your laminating rollers are possibly the most advanced heated laminating roller in the industry they are engineered (and patented) specifically for high performance, high quality, energy efficiency, and ease of operation. They are manufactured from some of the best materials available, for their application, to the industry utilizing technologies only developed in the last few years. We are constantly developing new technologies and formulas for our laminators to meet the extreme demands of the laminating process.

### **Roller Failure:**

The following most often causes this:

- Overheating the rollers
- Exceeding the designed speed and temperature for the specific film
- Cutting the rollers with a knife or other sharp object
- Failure to clean the rollers regularly resulting in the adhesive “burning” into the rollers thus causing the molecular link in the silicone to fail resulting in pitting on the roller surface.
- Running the laminator cold with an adhesive build up on the rollers. When the adhesive is cold, it will adhere to the laminating film and the silicone if you are using a film with a highly aggressive adhesive it is possible that it will pull on the silicone rollers causing pitting near the edges of the film. We have engineered silicones with high release capabilities and have nearly eliminated this problem however it may still occur when you combine this issue with the previous issue of “burn in”.

## **Operating Guidelines:**

### **Temperature:**

1. Never exceed 300 degrees set temperature or displayed temperature when operating the laminator.
2. Do not set the temperature control more than 20 degrees above the recommended temperature of the film and never above 300.
3. Remember, since your laminator takes about 5minutes to warm up it is unnecessary to leave the laminator turned on while it is not in use.
4. While in operation take note of the displayed temperature before you start laminating, if you see that the displayed temperature has dropped and is unable to achieve it prior setting slow the motor on the laminator – your film type and material has too high of a heat demand. Don't confuse this with temperature fluctuation (extreme, dramatic variations in temperature that change by tens or hundreds of degrees \*see maintenance), or cycling (successive changes in temperature up or down due to the heater turning on or off usually varies by no more than 5 degrees one or two degrees at a time and will always “crossover” or meet the correct temperature)

### **Film:**

1. Use laminating film as wide as possible and never less than half the width of the roller. (It would be ideal to use film that is the same width or ¼” wider than the roller width.) When using narrow film operate the laminator slower than its capabilities.
2. The lower the temperatures of the rollers the longer they will last keep this in mind when ordering film. For example: We would recommend a film that is rated at 250 degrees rather than 290 though this is not a rule in any way.
3. Take several moments to make absolute sure when you load the film on the machine that the adhesive side of the film DOES NOT touch the rollers. The few seconds that it takes to do this will save a tremendous amount of time in cleaning off the adhesive
4. When using your laminator for one-sided applications you must follow guidelines provided for you in your manual. Use the top roller for one sided applications
5. Always keep the film in the general center of the roller.

### **Cleaning:**

9. Never use an abrasive material on the roller this could cause damage contact pro-lam technical support before attempting this.
10. Never use solvents not specifically recommended for cleaning heated silicone laminating rollers.
11. Professional Laminating Systems recommends using methyl alcohol (methanol) or DX330 manufactured By PPG both of these products are flammable and toxic and should

be used with extreme caution in a well-ventilated area with the machine disconnected and no flame source.

12. Pro-Lam recommends using a course cotton mechanics cloth (NAPA part # 7601036).
13. Remove the film from the machine
14. Heat the laminator about 10 degrees beyond its normal set point (no hotter than 310 degrees). Keep in mind that the rollers get really hot and can easily burn you, wear loose fitting thick leather gloves if necessary, welding gloves can be purchased from your local welding supply, Grainger or NAPA.
15. Disconnect the Laminator and “wipe” off the adhesive using the course cotton cloth this may take a bit of work depending on the amount of time that the adhesive has been on the rollers and the type of adhesive it is it may also be necessary to reheat the machine if it cools
16. If you find it necessary to use a roller wash to clean your rollers, follow all safety guidelines applicable to the process.
17. Allow the machine to cool and then use methanol or DX330 to remove any dust and grease from the rollers

**Film Wrap**

1. DO NOT use an knife or any object that can damage the rollers to remove the film from the rollers
2. Heat the machine to operating temperature.
3. Remove any film, from the machine, that can be removed (supply rolls, tail, etc.), keep track of the end (or beginning) of the film wrap this will be where you start.
4. Very carefully cut the film between the front roller and back roller (if there is any) Remove the film from the non-offending roller.
5. Gap the rollers
6. Find the end (or beginning) of the film wrap and unwrap the film from the roller. This may take some time and be quite tedious you may have to use the motor to move the roller forward or back
7. Once you have removed the film you will have to clean the rollers refer to roller cleaning for this. It may be necessary to use the DX330 while the laminator is heated to remove the adhesive (follow all precautions, use respirator if necessary etc).

**Maintenance:**

- Clean rollers when it is necessary or at every film change.
- In the unusual occurrence of temperature fluctuation refer to the relevant paper regarding this or contact tech support.

## **Troubleshooting**

### **Overview**

Before any troubleshooting is made on the quality of the finished film, please confirm the following:

1. The rollers are clean and do not have excessive adhesive deposits.
2. The film used is of the same type, manufacture, thickness and temperature range.
3. Allow the laminator to cool to room temperature with the rollers gapped and then reheat - this will dissipate any cold or hot spots or rollers of unequal temperatures.
4. Make sure that the electrical circuit the laminator is connected to is of sufficient power and dedicated - This will prevent fuses from blowing and breakers from tripping.
5. Quickly inspect the laminator and its components for obvious failures or any broken components, i.e., Broken mandrel clips-loose or misaligned towers, functional idler rollers, ECT.

If the extent of your problem exceeds the documentation in this manual please find our online troubleshooting available at: [www.pro-lam.com](http://www.pro-lam.com)

Available online will be the latest in laminating troubleshooting and repair issues along with additional technical support on-line or via e-mail Or contact the dealer through whom this laminator was purchased.

### **Common Errors**

- Sliding idler in the down position or the film not properly threaded around it.
- Rollers Left gapped
- Film on backward (adhesive on the rollers)
- Incorrect temperature
- Fans not used
- Too much mandrel film tension
- Film curled around machine and blocking inflow of cooling air
- Incorrect tower alignment

**Rollers**

|   |  |
|---|--|
| Rollers cut, gouged, ripped, blistered, bubbled | Replace                                      |
| Erratic Temperature Fluctuation                 | Clean slip ring                              |
| Rollers cold when laminating                    | Slow down motor                              |
| Insufficient edge seal                          | Roller pressure                              |
| Wrinkling film                                  | Re-align towers, Add small amount of tension |
| Will not stop heating                           | Unplug+ Contact technical support            |
| Will not heat                                   | Contact technical support                    |

**Motor**

|                         |  |
|-------------------------|--|
| Erratic speed, low      | Set too slow,                                |
| Erratic speed, mid,     | Contact tech support                         |
| Erratic speed, All      | Reduce mandrel tension, contact tech support |
| Will not run            | Check switch, dial, and fuses                |
| Noise / runs at minimum | Contact Tech support                         |

**Temperature**

|                                      |                                   |
|--------------------------------------|-----------------------------------|
| Erratic Temperature Fluctuation      | Clean slip ring                   |
| Will not heat beyond “X” temperature | Contact Tech support              |
| Will not stop heating                | Unplug+ Contact technical support |
| Will not heat                        | Contact technical support         |
| Not enough heat                      | Slow motor down                   |

**Display**

|   |   |
|---|---|
| Erratic temperature Fluctuation                 | Clean slip ring   |
| Display shows -1                                | Shorted signal from sensor  |
| Display shows 1                                 | Open signal from sensor   |
| Display shows 440 degrees+                      | Shorted signal  |
| Display shows nothing                           | Turn on heat  |
| Display shows “Bat”                             | Incorrect voltage, unplug, contact tech support                       |
| Shows temperature much different than set point | Allow machine to sit idle if it does not recover contact tech support |

**Other**

|   |                                    |
|---|------------------------------------|
| No function                             | Check fuses and breakers – plug in |
| Switch works – light does not light     | Replace                            |
| Motor drive chain makes noise           | Misaligned sprockets – loose chain |
| Mandrels do not hold film from slipping | Wrong mandrel / broken clip        |
|   |                                    |

**Film**

Typical problems, Follow list for topic in sequence, the first solution will be the most common.

|   |   |
|---|---|
| Film is foggy, on rollers and in lamination         | Decrease speed                                    |
|   | Increase temperature                              |
|   | Defective Film                                    |
| Film is foggy, clear on rollers foggy in lamination | Decrease temperature                              |
|   | Defective Film                                    |
| Film does not stick / poor bond                     | Decrease speed                                    |
|   | Increase temperature                              |
|   | Increase roller Pressure                          |
|   | Incompatible film adhesive with project           |
|   | Defective Film                                    |
| Bubbles / air pockets in film only, not near edge   | Film is not running flat at nip, increase tension |
|   | Film is not running flat at nip, decrease tension |
|   | Not enough pressure for application, increase     |
|   | To much pressure (rollers bending), decrease      |
|   | Defective Film                                    |
| Bubbles / air pockets in lamination                 | See troubleshooting for film                      |
|   | Defective Film                                    |
| Bubbles in edge seal                                | Not enough pressure available, increase           |
|   | Paper to thick for film / laminator               |
|   | Speed to great to conform, Slower                 |
|   | Temperature to low for adhesive flow, increase    |
|   | Film to thin for adhesive flow                    |
| Bubbles between sheets perpendicular to rollers     | Not enough pressure available, increase           |
|   | To much pressure (rollers bending), decrease      |
|   | Film to thin for adhesive flow                    |
|   | Temperature to low for adhesive flow, increase    |
|   | Sheets to close, allow more space                 |
| Bubbles in edge seal parallel to the rollers        | Too hot, decrease temperature                     |

|  |  |
|--|--|
| Blistering / random bubbles on paper           | Too hot, decrease temperature                        |
|  | Paper moisture content too high                      |
|  | Incompatible film / temperature for the ink used     |
|  | Defective Film                                       |
| Optical distortion in film / wavy / puddles    | Too hot for film base, decrease temperature          |
|  | Too slow – Film base distorting, speed up            |
|  | Too Much Pressure, decrease                          |
|  | Defective Film                                       |
| Optical distortion in film parallel to rollers | Motor pulsating, increase speed                      |
|  | Motor pulsating, reduce mandrel tension              |
|  | Supply roll bouncing, increase mandrel tension       |
|  | Film stretching and rebounding, decrease tension     |
|  | Roller pressure too great, reduce                    |
| Irregular bonding                              | Decrease speed                                       |
|  | Increase roller pressure                             |
|  | Defective Film                                       |
| Stretch marks                                  | Decrease mandrel tensions                            |
|  | Decrease rear rollers Pressure                       |
|  | Defective film                                       |
| Curl up  | Decrease top mandrel tension                         |
|  | Increase lower mandrel tension                       |
|  | Turn on / off fans                                   |
|  | Defective film                                       |
|  | Increase rear roller pressure                        |
|  |  |
| Curl down                                      | Decrease Lower mandrel tension                       |
|  | Increase upper Mandrel Tension                       |
|  | Turn off / on fans                                   |
|  | Decrease rear roller pressure                        |
|  | Defective film                                       |
| Twist in film                                  | Uneven roller pressures right to left /front to back |
|  | Unmatched film buy matched film rolls (rare)         |
|  | Defective film                                       |
| Waves in film perpendicular to rollers         | Turn sheet sideways, paper grain wrong               |
|  | Too hot, decrease temperature                        |



|  |  |
|--|--|
|  | Check film alignment                               |
|  | Increase rear roller pressure                      |
|  | Incompatible paper, paper shrinking excessively    |
|  | Moisture content incorrect, preheat / temper paper |
|  | Paper shrinking, preheat / temper                  |
|  | Moisture content incorrect, let paper stabilize    |
|  | Incompatible film                                  |
|  | Defective film                                     |
| Waves in film at angles                | Incompatible paper                                 |
|  | Too hot for paper / ink                            |
|  | Check film alignment                               |
|  | Incorrect roller pressures, decrease pressure      |
|  | Incorrect mandrel tension, decrease tension        |
|  | Defective Film                                     |
| Waves in film perpendicular to rollers | Insufficient rear roller pressure, increase        |
|  | Speed up motor                                     |
|  | Check film alignment                               |
| Waves, small, in edge seal             | Increase film thickness                            |
|  | Decrease paper thickness                           |
|  | Decrease roller pressures                          |
|  |  |
|  |  |
|  |  |
|  |  |
|  |  |
|  |  |





## LIMITED WARRANTY

### THE WARRANTY

This warranty is only valid in the USA and for military installation world wide. You must register you machine with Pro-Lam upon receipt of your machine.

Professional Laminating Systems Inc. (referred to as "Pro-Lam") warrants this laminator frame to be free from defects in material and/or workmanship for a period of One (1) year from the date of its original purchase.

All electrical parts and rubber rollers are warranted free from defects in a material and/or work-man ship for a period of ninety (90) days from the date of its original purchase for use.

This warranty does not cover damage or failure caused by or attributable to negligence, acts of god, abuse, misuse, improper or abnormal usage, faulty installation, improper maintenance, lightening or other incidence of excess or abnormal voltage.

Pro-lam is not responsible or liable for indirect, special, or consequential damages arising out of or in connection with the use or performance of the product or other damages with respect to loss of property, loss of revenue or profit, or cost of removal, installation of reinstallation

In the event of a defect in material or workmanship during the warranty period Pro-Lam and/or its authorized dealer, will repair or replace (at its option) your laminator under the conditions of this warranty. If the machine is sent to Pro-Lam we will repair the machine at our facility, at our expense for the cost of labor and materials but not for shipping and delivery charges.

### LIMITATIONS, EXCLUSIONS AND OTHER RIGHTS:

Pro-Lam disclaims liability for implied warranties of merchantability, fitness for any particular purpose, or otherwise, after the terms of this warranty.

Some states do not allow limitations on how long an implied warranty lasts, so the above limitation may not apply to you.

### **Eligibility:**

This warranty is only eligible to the initial owner and is not transferable or negotiable.

To validate your warranty, register you machine with Pro-Lam upon receipt of your machine

## CLAIM PROCEDURE

If you discover a defect or malfunction during the period to which this warranty applies, you must follow this procedure:

- Contact the Pro-Lam Dealer from whom the laminator was purchased and they will handle your warranty issues for you.
- Or, contact Pro-Lam 1806 hwy. 93 Hamilton MT 59840 or fax 406-363-1690 and explain the reason why you believe there is a defect or malfunction in the laminator including the date and conditions under which the defect or malfunction occurred.
- Include in your letter a copy of the sales slip or other proof of date or purchase of the laminator. Or the warranty starts from the date of which it was manufactured

Upon receipt of your letter, Pro-Lam or the said distributor will make a preliminary determination of its responsibility to repair or replace under this Warranty.

If Pro-Lam denies responsibility, it will explain its decision in writing. You may then submit new or additional facts or request information on repair of the laminator at your own expense.

If Pro-Lam accepts responsibility, it will notify you in writing to bring or ship, at your expense, the laminator to Pro-Lam. Optionally, the customer or Pro-lam may also choose to send the part to the location of the machine for on-site service by either the customer or the dealer

When Pro-Lam receives the laminator (under no conditions is Pro-Lam responsible for damage in transit), it may then determine upon inspection that this warranty does or does not apply.

If the warranty does not apply, you will be told the reason and the cost to you of repair and return. You must then authorize Pro-Lam or the said distributor to make the repairs and/or return the laminator to you.

Include with your authorization a purchase order or bank check or money order to cover all costs. (Please note: personal checks must clear the bank before the repairs are begun.) If you fail to, do so within sixty (60) days of Pro-Lam's notice to you, Pro-Lam is free to return the laminator to you C.O.D. for you to pay the shipping cost on delivery.

If you fail to pay C.O.D. charges and the laminator is returned to Pro-Lam, we will then dispose of it.

# #6 Conversion Tables:

## Temperature: Celsius to Fahrenheit

| Celsius | Fahrenheit | Celsius | Fahrenheit | Celsius | Fahrenheit |
|---------|------------|---------|------------|---------|------------|
| 38      | 100        | 114     | 237        | 190     | 374        |
| 40      | 104        | 116     | 241        | 192     | 378        |
| 42      | 108        | 118     | 244        | 194     | 381        |
| 44      | 111        | 120     | 248        | 196     | 385        |
| 46      | 115        | 122     | 252        | 198     | 388        |
| 48      | 118        | 124     | 255        | 200     | 392        |
| 50      | 122        | 126     | 259        | 202     | 396        |
| 52      | 126        | 128     | 262        | 204     | 399        |
| 54      | 129        | 130     | 266        | 206     | 403        |
| 56      | 133        | 132     | 270        | 208     | 406        |
| 58      | 136        | 134     | 273        | 210     | 410        |
| 60      | 140        | 136     | 277        | 212     | 414        |
| 62      | 144        | 138     | 280        | 214     | 417        |
| 64      | 147        | 140     | 284        | 216     | 421        |
| 66      | 151        | 142     | 288        | 218     | 424        |
| 68      | 154        | 144     | 291        | 220     | 428        |
| 70      | 158        | 146     | 295        | 222     | 432        |
| 72      | 162        | 148     | 298        | 224     | 435        |
| 74      | 165        | 150     | 302        | 226     | 439        |
| 76      | 169        | 152     | 306        | 228     | 442        |
| 78      | 172        | 154     | 309        | 230     | 446        |
| 80      | 176        | 156     | 313        | 232     | 450        |
| 82      | 180        | 158     | 316        | 234     | 453        |
| 84      | 183        | 160     | 320        | 236     | 457        |
| 86      | 187        | 162     | 324        | 238     | 460        |
| 88      | 190        | 164     | 327        | 240     | 464        |
| 90      | 194        | 166     | 331        | 242     | 468        |
| 92      | 198        | 168     | 334        | 244     | 471        |
| 94      | 201        | 170     | 338        | 246     | 475        |
| 96      | 205        | 172     | 342        | 248     | 478        |
| 98      | 208        | 174     | 345        | 250     | 482        |
| 100     | 212        | 176     | 349        | 252     | 486        |
| 102     | 216        | 178     | 352        | 254     | 489        |
| 104     | 219        | 180     | 356        | 256     | 493        |
| 106     | 223        | 182     | 360        | 258     | 496        |
| 108     | 226        | 184     | 363        | 260     | 500        |
| 110     | 230        | 186     | 367        | 262     | 504        |
| 112     | 234        | 188     | 370        | 264     | 507        |

**Length:EU to SI**

| Inch  | mm  |
|-------|-----|
| 0.005 | 0.1 |
| 0.010 | 0.3 |
| 0.015 | 0.4 |
| 0.020 | 0.5 |
| 0.025 | 0.6 |
| 0.030 | 0.8 |
| 0.035 | 0.9 |
| 0.040 | 1.0 |
| 0.045 | 1.1 |
| 0.050 | 1.3 |
| 0.055 | 1.4 |
| 0.060 | 1.5 |
| 0.065 | 1.7 |
| 0.070 | 1.8 |
| 0.075 | 1.9 |
| 0.080 | 2.0 |
| 0.085 | 2.2 |
| 0.090 | 2.3 |
| 0.095 | 2.4 |
| 0.100 | 2.5 |
| 0.105 | 2.7 |
| 0.110 | 2.8 |
| 0.115 | 2.9 |
| 0.120 | 3.0 |
| 0.125 | 3.2 |
| 0.130 | 3.3 |
| 0.135 | 3.4 |
| 0.140 | 3.6 |
| 0.145 | 3.7 |
| 0.150 | 3.8 |
| 0.155 | 3.9 |
| 0.160 | 4.1 |
| 0.165 | 4.2 |
| 0.170 | 4.3 |
| 0.175 | 4.4 |
| 0.180 | 4.6 |
| 0.185 | 4.7 |
| 0.190 | 4.8 |
| 0.195 | 5.0 |
| 0.200 | 5.1 |
| 0.205 | 5.2 |
| 0.210 | 5.3 |
| 0.215 | 5.5 |
| 0.220 | 5.6 |
| 0.225 | 5.7 |
| 0.230 | 5.8 |
| 0.235 | 6.0 |
| 0.240 | 6.1 |
| 0.245 | 6.2 |
| 0.250 | 6.4 |

| Inch  | mm   |
|-------|------|
| 0.255 | 6.5  |
| 0.260 | 6.6  |
| 0.265 | 6.7  |
| 0.270 | 6.9  |
| 0.275 | 7.0  |
| 0.280 | 7.1  |
| 0.285 | 7.2  |
| 0.290 | 7.4  |
| 0.295 | 7.5  |
| 0.300 | 7.6  |
| 0.305 | 7.7  |
| 0.310 | 7.9  |
| 0.315 | 8.0  |
| 0.320 | 8.1  |
| 0.325 | 8.3  |
| 0.330 | 8.4  |
| 0.335 | 8.5  |
| 0.340 | 8.6  |
| 0.345 | 8.8  |
| 0.350 | 8.9  |
| 0.355 | 9.0  |
| 0.360 | 9.1  |
| 0.365 | 9.3  |
| 0.370 | 9.4  |
| 0.375 | 9.5  |
| 0.380 | 9.7  |
| 0.385 | 9.8  |
| 0.390 | 9.9  |
| 0.395 | 10.0 |
| 0.400 | 10.2 |
| 0.405 | 10.3 |
| 0.410 | 10.4 |
| 0.415 | 10.5 |
| 0.420 | 10.7 |
| 0.425 | 10.8 |
| 0.430 | 10.9 |
| 0.435 | 11.0 |
| 0.440 | 11.2 |
| 0.445 | 11.3 |
| 0.450 | 11.4 |
| 0.455 | 11.6 |
| 0.460 | 11.7 |
| 0.465 | 11.8 |
| 0.470 | 11.9 |
| 0.475 | 12.1 |
| 0.480 | 12.2 |
| 0.485 | 12.3 |
| 0.490 | 12.4 |
| 0.495 | 12.6 |
| 0.500 | 12.7 |

| Inch  | mm   |
|-------|------|
| 0.505 | 12.8 |
| 0.510 | 13.0 |
| 0.515 | 13.1 |
| 0.520 | 13.2 |
| 0.525 | 13.3 |
| 0.530 | 13.5 |
| 0.535 | 13.6 |
| 0.540 | 13.7 |
| 0.545 | 13.8 |
| 0.550 | 14.0 |
| 0.555 | 14.1 |
| 0.560 | 14.2 |
| 0.565 | 14.4 |
| 0.570 | 14.5 |
| 0.575 | 14.6 |
| 0.580 | 14.7 |
| 0.585 | 14.9 |
| 0.590 | 15.0 |
| 0.595 | 15.1 |
| 0.600 | 15.2 |
| 0.605 | 15.4 |
| 0.610 | 15.5 |
| 0.615 | 15.6 |
| 0.620 | 15.7 |
| 0.625 | 15.9 |
| 0.630 | 16.0 |
| 0.635 | 16.1 |
| 0.640 | 16.3 |
| 0.645 | 16.4 |
| 0.650 | 16.5 |
| 0.655 | 16.6 |
| 0.660 | 16.8 |
| 0.665 | 16.9 |
| 0.670 | 17.0 |
| 0.675 | 17.1 |
| 0.680 | 17.3 |
| 0.685 | 17.4 |
| 0.690 | 17.5 |
| 0.695 | 17.7 |
| 0.700 | 17.8 |
| 0.705 | 17.9 |
| 0.710 | 18.0 |
| 0.715 | 18.2 |
| 0.720 | 18.3 |
| 0.725 | 18.4 |
| 0.730 | 18.5 |
| 0.735 | 18.7 |
| 0.740 | 18.8 |
| 0.745 | 18.9 |
| 0.750 | 19.1 |

| Inch  | mm   |
|-------|------|
| 0.755 | 19.2 |
| 0.760 | 19.3 |
| 0.765 | 19.4 |
| 0.770 | 19.6 |
| 0.775 | 19.7 |
| 0.780 | 19.8 |
| 0.785 | 19.9 |
| 0.790 | 20.1 |
| 0.795 | 20.2 |
| 0.800 | 20.3 |
| 0.805 | 20.4 |
| 0.810 | 20.6 |
| 0.815 | 20.7 |
| 0.820 | 20.8 |
| 0.825 | 21.0 |
| 0.830 | 21.1 |
| 0.835 | 21.2 |
| 0.840 | 21.3 |
| 0.845 | 21.5 |
| 0.850 | 21.6 |
| 0.855 | 21.7 |
| 0.860 | 21.8 |
| 0.865 | 22.0 |
| 0.870 | 22.1 |
| 0.875 | 22.2 |
| 0.880 | 22.4 |
| 0.885 | 22.5 |
| 0.890 | 22.6 |
| 0.895 | 22.7 |
| 0.900 | 22.9 |
| 0.905 | 23.0 |
| 0.910 | 23.1 |
| 0.915 | 23.2 |
| 0.920 | 23.4 |
| 0.925 | 23.5 |
| 0.930 | 23.6 |
| 0.935 | 23.7 |
| 0.940 | 23.9 |
| 0.945 | 24.0 |
| 0.950 | 24.1 |
| 0.955 | 24.3 |
| 0.960 | 24.4 |
| 0.965 | 24.5 |
| 0.970 | 24.6 |
| 0.975 | 24.8 |
| 0.980 | 24.9 |
| 0.985 | 25.0 |
| 0.990 | 25.1 |
| 0.995 | 25.3 |
| 1.000 | 25.4 |